

CE EN IEC 60598-1 IEC/TR 62778 650°C IP20

DRIVER/LED : SELV

Cod.	3F Travetta LED DI Sensor LGS	
10765	3F Travetta LED DI 2x24W Sensor LGS L1290	4.0
10766	3F Travetta LED DI 2x30W Sensor LGS L1590	5.0

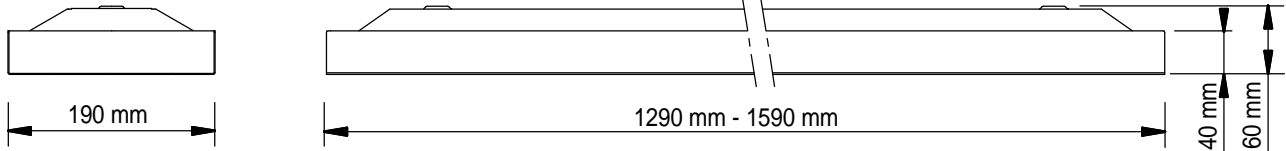

- ATTENZIONE : Non toccare i moduli Led - Maneggiare con cautela
Dispositivo sensibile alle scariche elettrostatiche - Usare guanti antistatici
Non esporre i moduli LED a polveri e/o sostanze chimicamente aggressive
quali Cloro, Zolfo, Ammoniaca, Oli Minerali, ecc.

- ATTENTION : Ne touchez pas les modules Led - Manipuler avec précaution
Dispositif sensible aux décharges électrostatiques - Utiliser gants antistatiques
N'exposez pas les modules LED aux poussières et/ou aux produits chimiques
agressifs comme chlore, soufre, ammoniac, huiles minérales, etc.

- ATENCION : No toque los módulos Led - Tratar con cuidado
Dispositivo sensible a las descargas electrostáticas - Use guantes antiestáticos
No exponga los módulos LED a polvos y/o sustancias químicamente agresivas
como cloro, azufre, amoníaco, aceites minerales, etc.

- ATTENTION : Do not touch the Led modules - Observe precautions for handling
Device sensitive to electrostatic discharge - Use antistatic gloves
Do not expose LED modules to dust and/or chemically aggressive substances
such as Chlorine, Sulphur, Ammonia, Mineral Oils, etc.

- ACHTUNG : LED-module nicht berühren - mit Vorsicht behandeln
Gerät empfindlich gegen elektrostatiscche Entladung - Verwenden Sie antistatische
Handschuhe
Setzen Sie die LED-Module keinen Staubpartikeln und/oder aggressiven
chemischen Substanzen wie Chlor, Schwefel, Ammoniak, Mineralölen usw. aus.



Sorgente luminosa (solo LED) sostituibile da un professionista
Replaceable (LED only) light source by a professional
Source lumineuse (LED uniquement) remplaçable par un professionnel
Fuente luminosa reemplazable (solo LED) por un profesional
Austauschbare (nur LED) Lichtquelle durch einen Fachmann



Alimentatore sostituibile da un professionista
Replaceable control gear by a professional
Boîtier de commande remplaçable par un professionnel
Equipo de control reemplazable por un profesional
Austauschbare Vorschaltgeräte durch einen Fachmann

This product contains a light source of energy efficiency class < <https://www.3f-filippi.com/en/Search> >
Questo prodotto contiene una sorgente luminosa di classe di efficienza energetica < <https://www.3f-filippi.com/it/Ricerca> >
Ce produit contient une source lumineuse de classe d'efficacité énergétique < <https://www.3f-filippi.com/fr/Recherche> >
Dieses Produkt enthält eine Lichtquelle der Energieeffizienzklasse < <https://www.3f-filippi.com/de/Suche> >
Este producto contiene una fuente de luz de clase de eficiencia energética < <https://www.3f-filippi.com/es/Busqueda> >

1

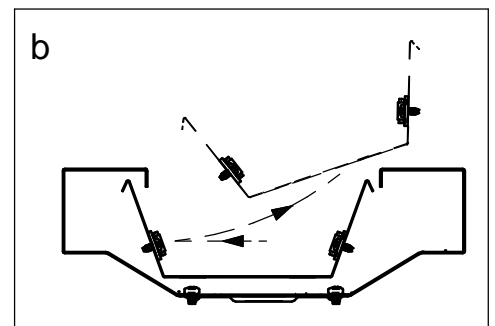
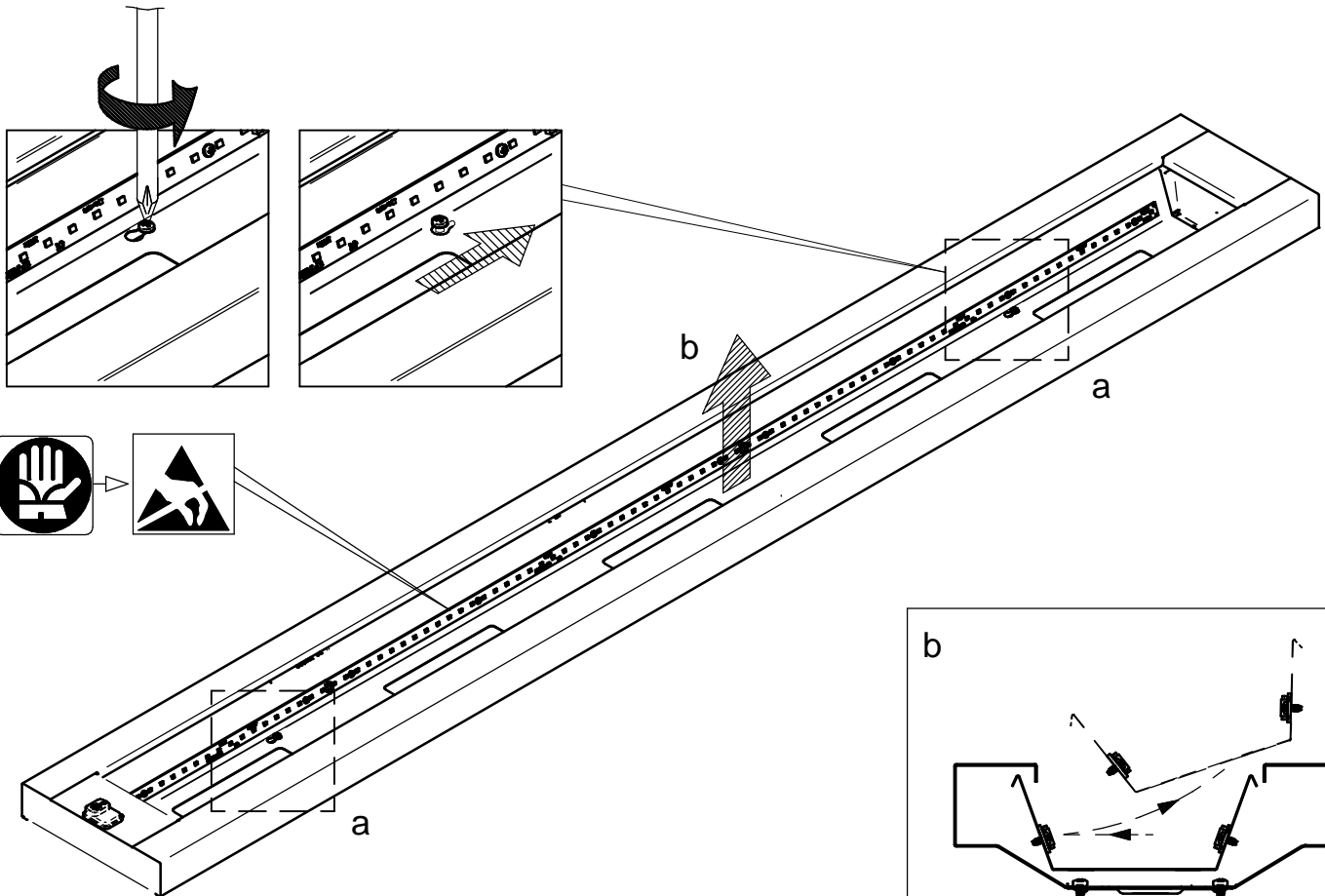

2

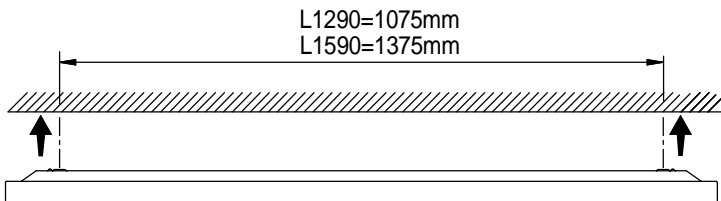
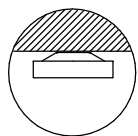

max 5 mm

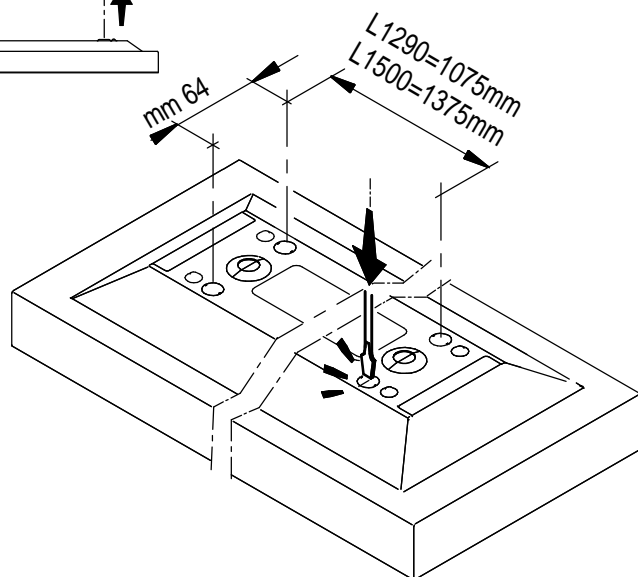
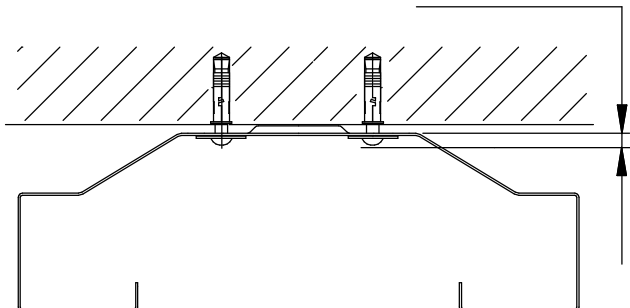

2/A

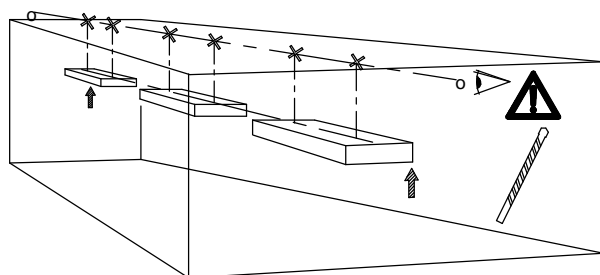
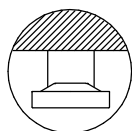

L1290=1250mm
L1590=1550mm

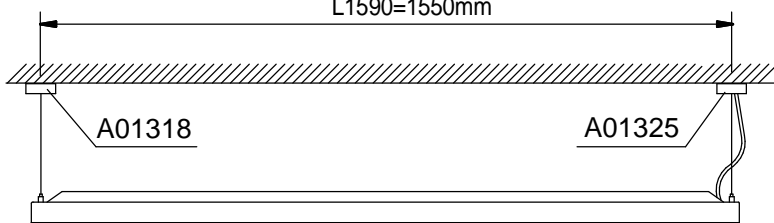
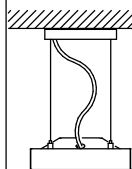

a

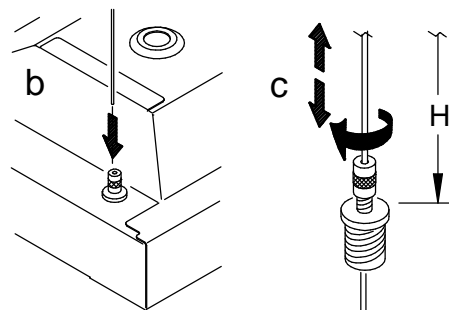
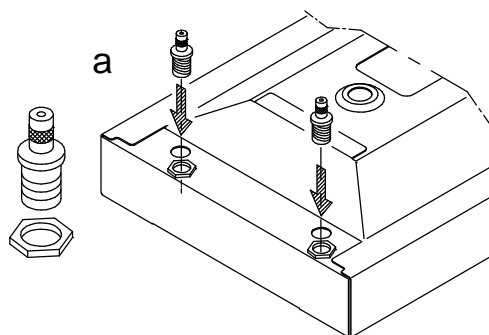

2/B

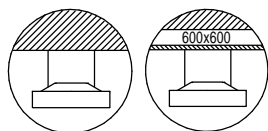

L1290=1200 mm

L1590=1200 mm

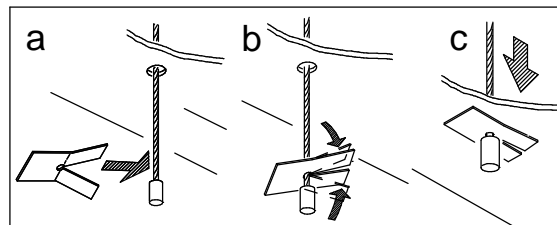
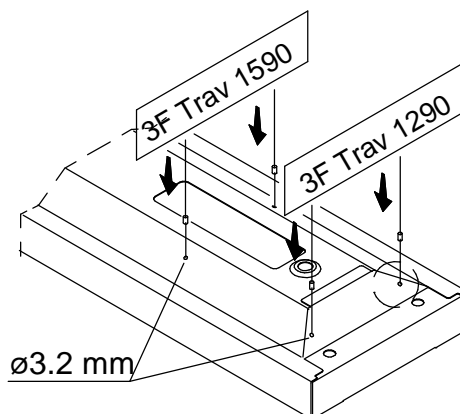
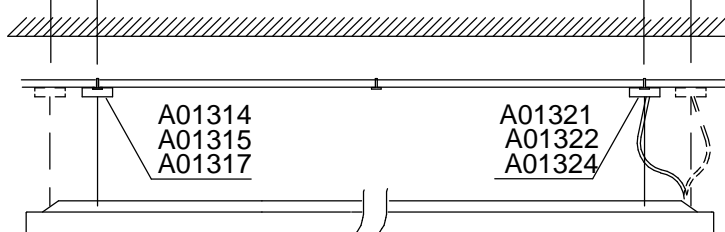
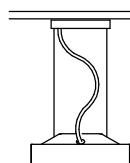

3

∅ min 9 mm
∅ max 10 mm
max 5 x 1.5 mmq

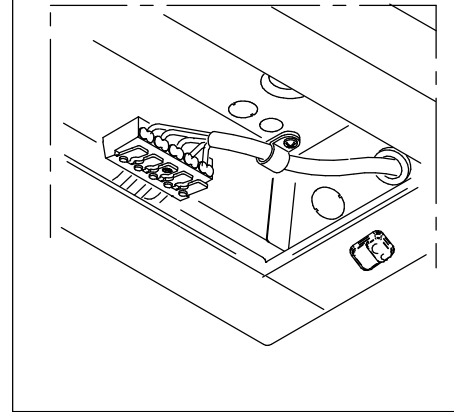
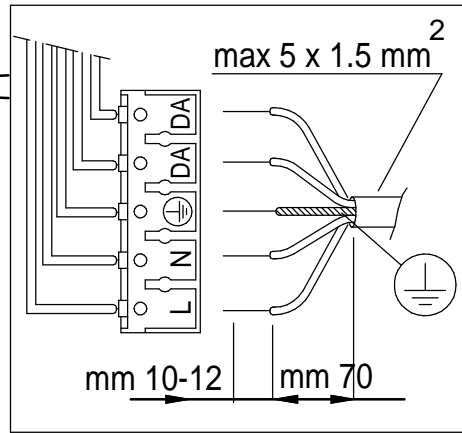
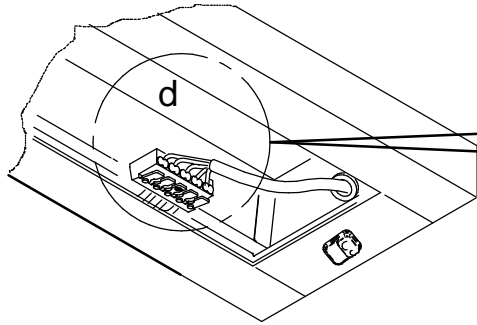
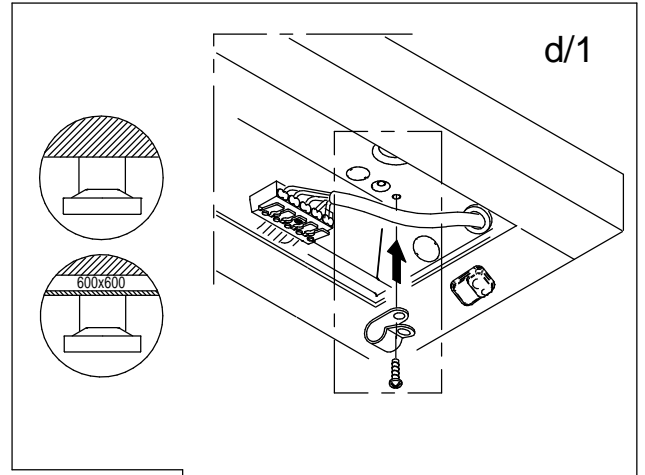
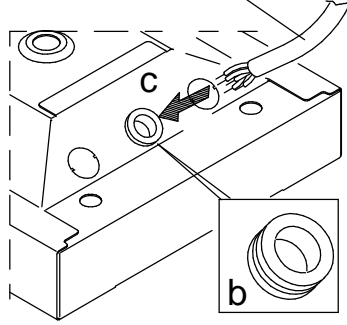
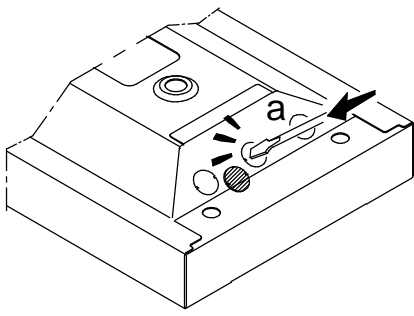

4 Application MASTER / SLAVE (Max 3)

➔ ⚠ NO TOUCH DIM

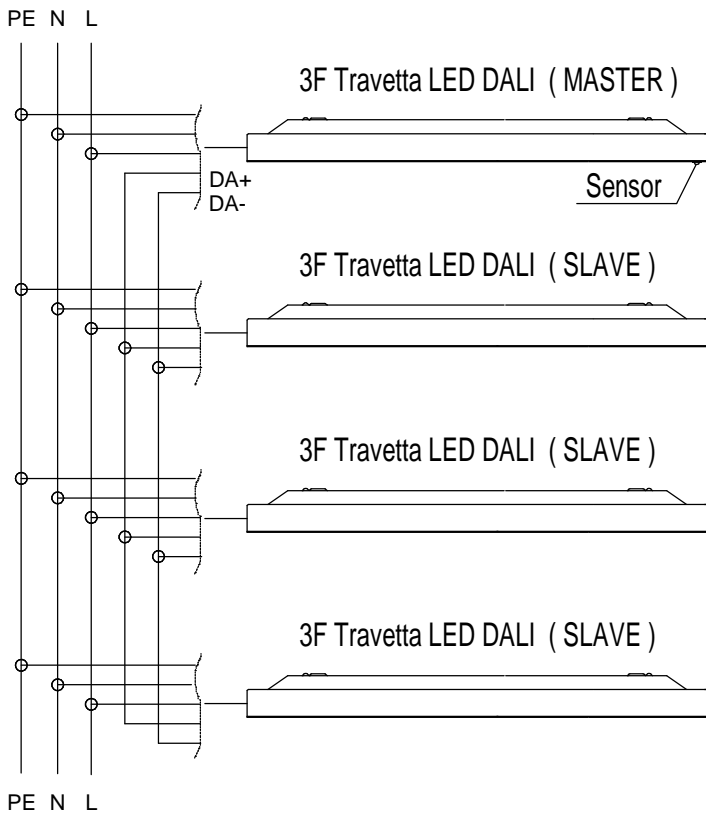

Application MASTER

➔ ⚠ NO TOUCH DIM

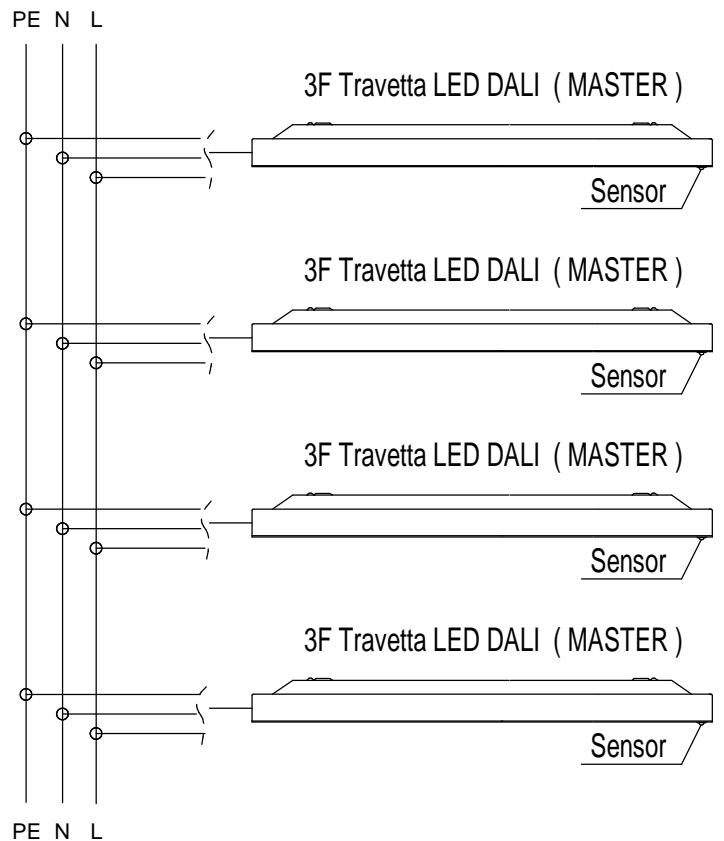

5

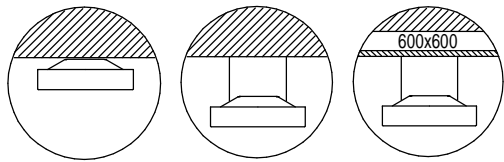

c

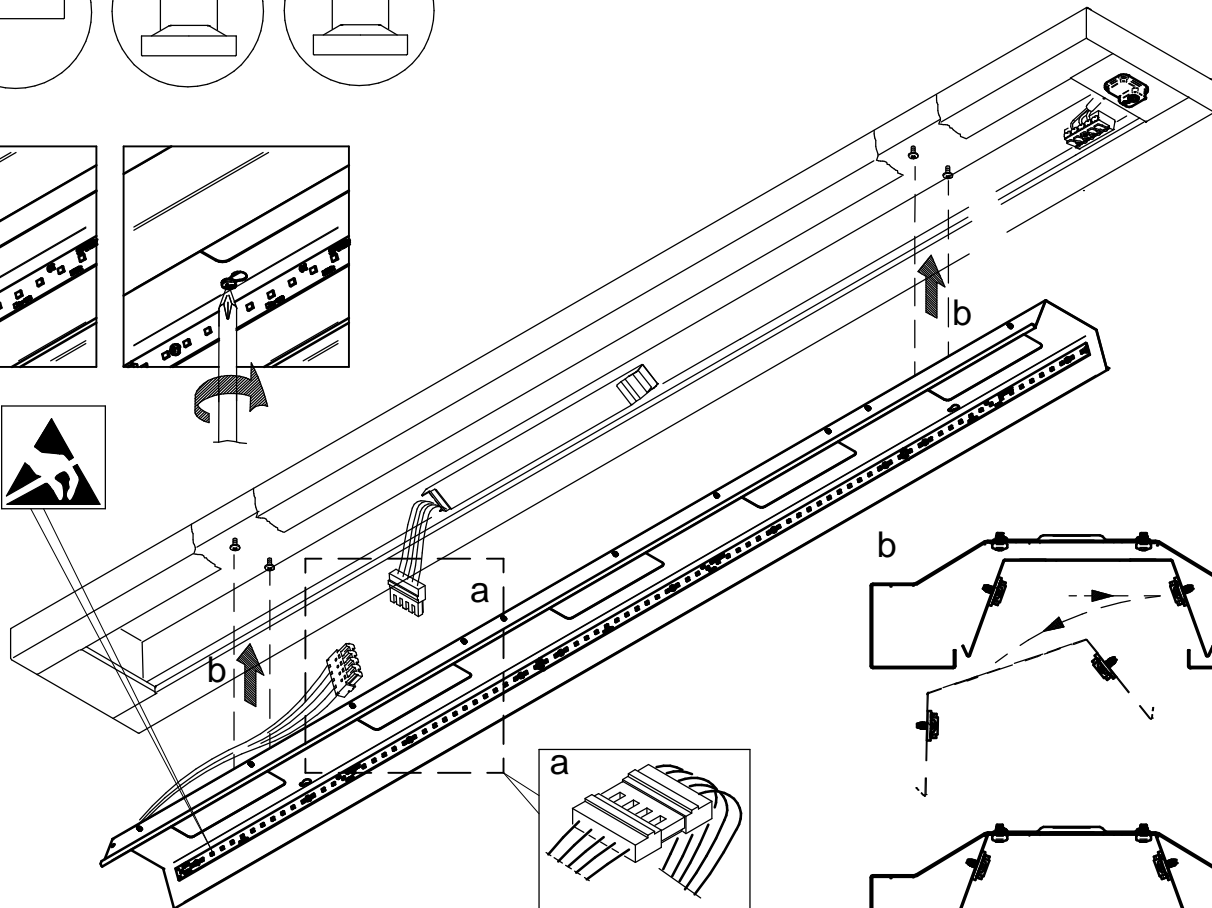
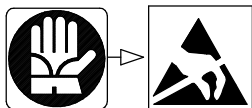
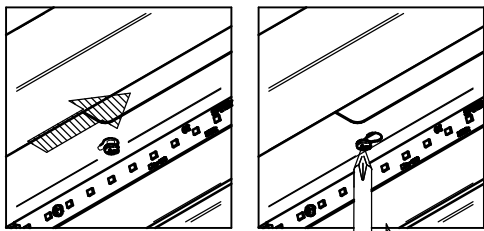

6

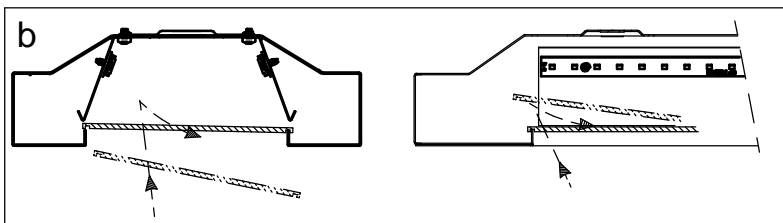
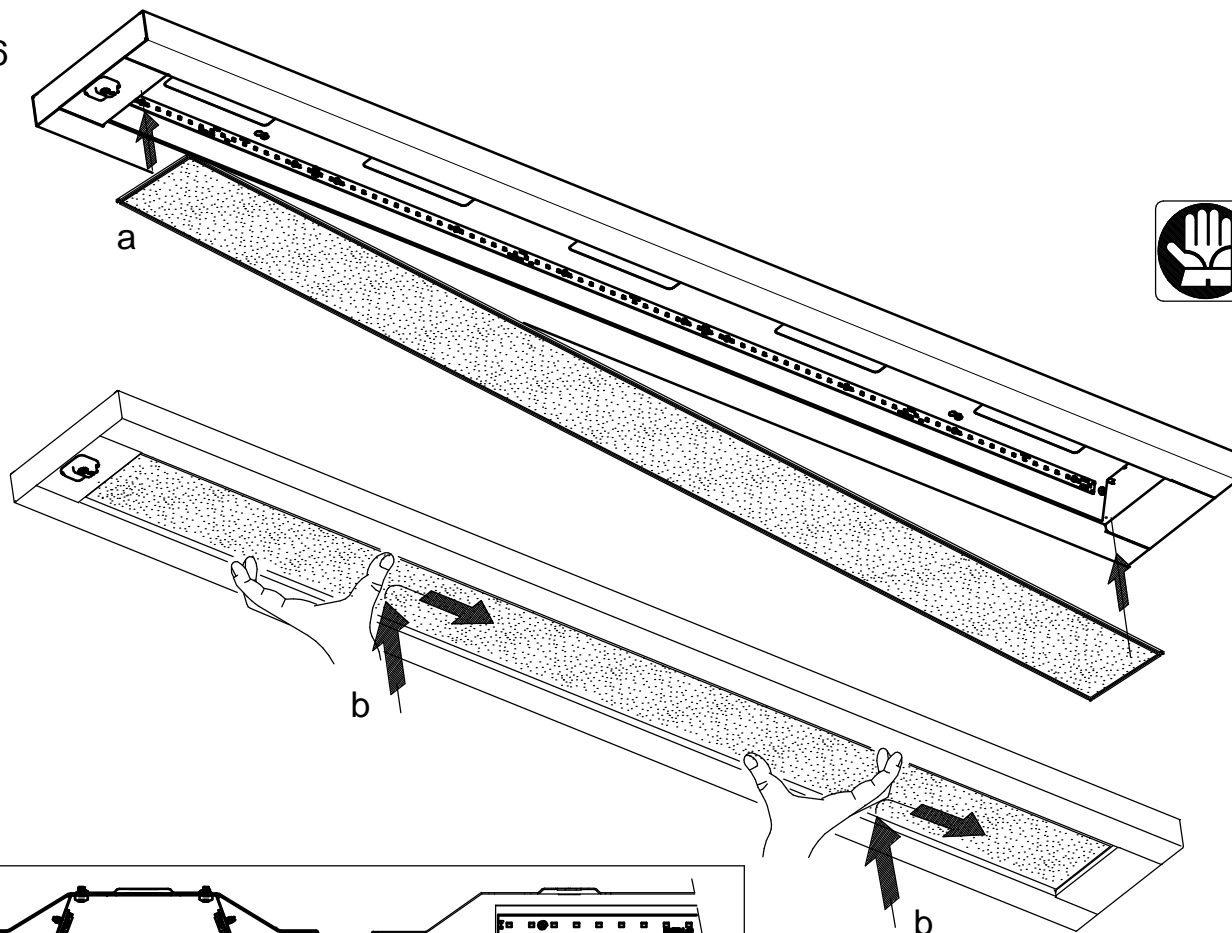

3F Filippi S.p.A., dichiara che il tipo di apparecchiatura radio SENSOR è conforme alla direttiva 2014/53/UE. Il testo completo della dichiarazione di conformità UE è disponibile al seguente indirizzo Internet: www.3f-filippi.it

3F Filippi S.p.A. declares that the type of radio equipment SENSOR is in compliance with 2014/53/UE directive. The full text of the EU Declaration of Conformity is available at the following Internet address: www.3f-filippi.it

3F Filippi S.p.A., déclare que le type d'équipement radioélectrique SENSOR est conforme à la directive 2014/53/EU. Le texte intégral de la déclaration UE de conformité est disponible à l'adresse Internet suivante: www.3f-filippi.it

3f-filippi.it 3F Filippi S.p.A. erkl rt, dass die Art von Funkger t SENSOR der Richtlinie 2014/53/EU entspricht. Die vollst ndige EU-Konformit tserkl rung ist auf folgender Internetseite zu lesen: www.3f-filippi.it

H	MB \emptyset FOV 108°	HB \emptyset FOV 62°
3 m	8,3 m	3,6 m
4 m	11,0 m	4,8 m
5 m	13,8 m	6,0 m
6 m	16,5 m	7,2 m
7 m	19,3 m	8,4 m
8 m	22,0 m	9,6 m
9 m	24,8 m	10,8 m
10 m	27,5 m	12,0 m
11 m	-	13,2 m
12 m	-	14,4 m
13 m	-	15,6 m
14 m	-	16,8 m
15 m	-	18,0 m
16 m	-	19,2 m
17 m	-	20,4 m

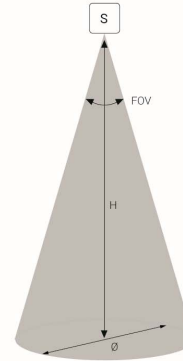

Z-PLUG-SENSOR-MB

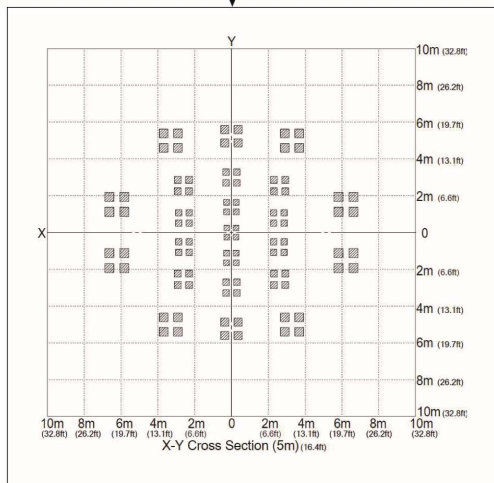

Z-PLUG-SENSOR-HB

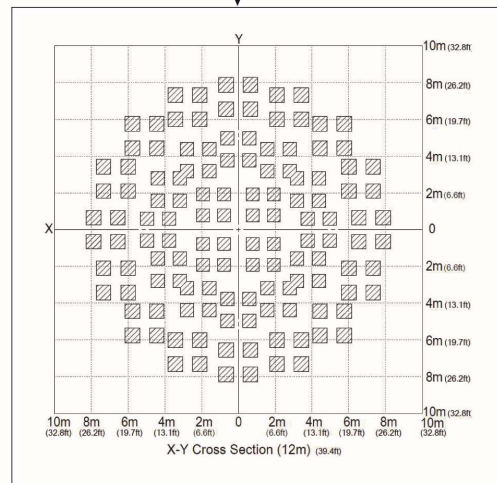

Banda di frequenza / Massima potenza RF trasmessa /
Operating frequency / Max RF output power
2.402 GHz — 2.480 GHz / +10 dBm

<https://zetaqlab.com/datasheets/zplughb.pdf>

L'apparecchio non deve essere smaltito come rifiuto urbano, mediante cassonetto, ma e' soggetto a raccolta separata.
Il mancato rispetto di questa norma e' sanzionato dalla legge e potrebbe provocare potenzialmente effetti negativi sia per l'ambiente sia sulla salute umana.

L'appareil ne doit pas  tre  limin  comme ordures m nag res, dans la poubelle, mais il est sujet   collecte s lective.
La non-observation de cette disposition est sanctionn e par la loi et peut provoquer en puissance effets n gatifs soit pour l'ambiance soit pour la sant  humaine.

La luminaria no debe ser desechada como residuo urbano, sino a trav s de un gestor de residuos, ya que es objeto de recogida selectiva.
El incumplimiento de esta norma est  sancionado por la ley y puede causar potencialmente da os tanto al medio ambiente como a la salud.



The luminaire must not be eliminated as urban waste, by means of refuse body, rather it is object of separate collection.
The non-observance of this rule is sanctioned by the law and potentially could cause negative effects both on the environment and on human health.

Die Leuchte muss als Sonderm ll entsorgt werden!
Die Nichteinhaltung dieser Bestimmung kann strafrechtlich verfolgt werden. Ferner verursacht eine nicht gerechte Entsorgung negative Folgen f r die Umwelt und die menschliche Gesundheit.

DECRETO LEGISLATIVO 14 marzo 2014, n. 49. Attuazione della direttiva 2012/19/UE (Revisione della Direttiva 2002/96/UE) e s.m.i.