



650°C

IP40

EN IEC 60598-1

IEC/EN 60598-2-22 "eme.3F-Filippi.com"

ART.	L	D	Kg Max
3F MILLUMINO VL L900	878	60	0,9
3F MILLUMINO VL L1500	1463	60	1,5
3F MILLUMINO VL L1800	1756	60	1,8
3F MILLUMINO VL L2200	2198	60	2,2
3F MILLUMINO VL L2800	2783	60	2,8
3F MILLUMINO VL L3400	3368	60	3,4

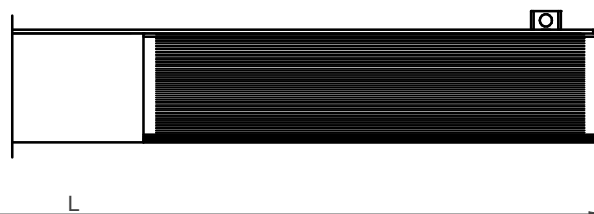
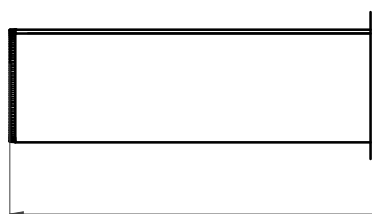
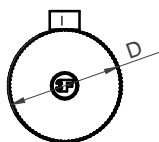

ART.	L	D	Kg Max
3F MILLUMINO VC L1500	1480	60	1,5
3F MILLUMINO VC 2800	2800	60	2,8
3F MILLUMINO VC L3400	3386	60	3,4

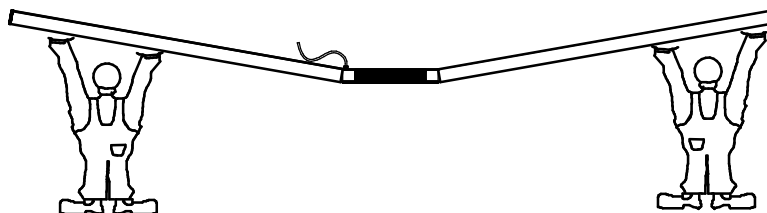
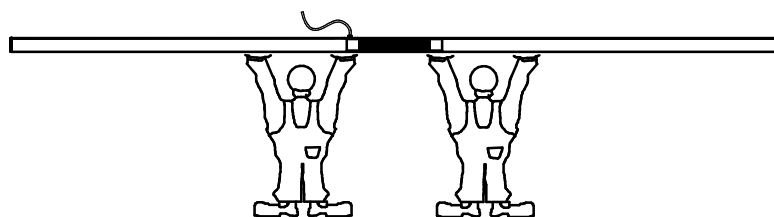
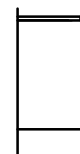
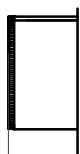
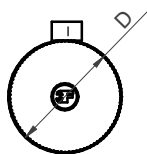

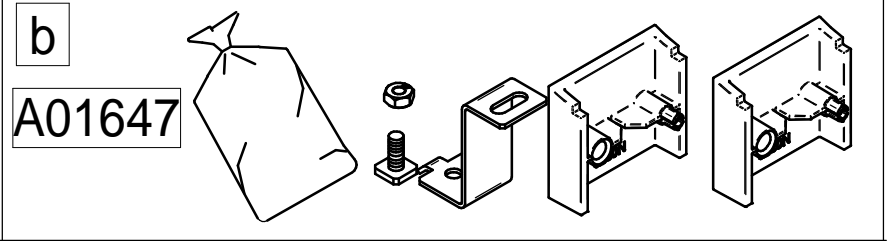
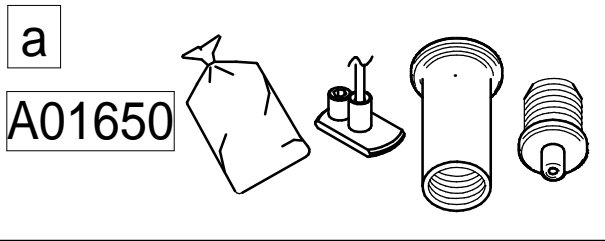

1/a

A01650

A01647

1/b

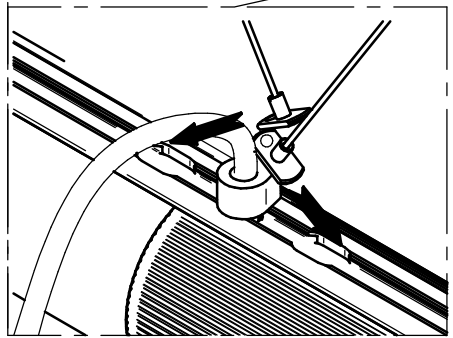
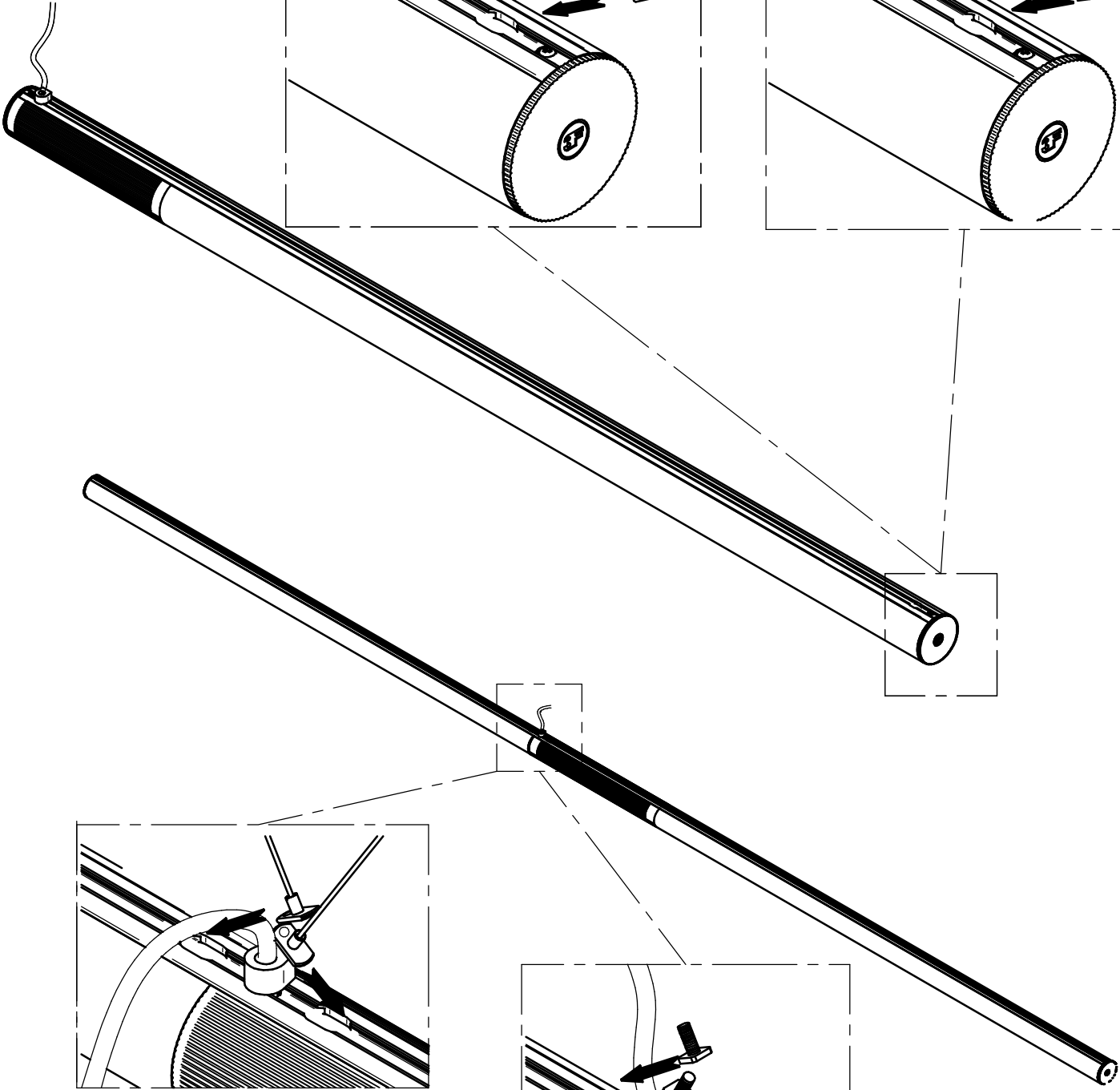
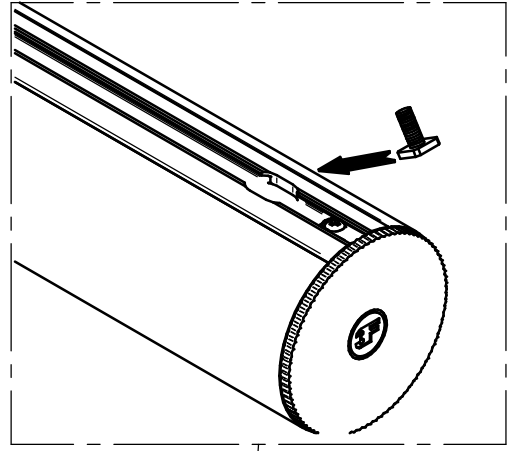
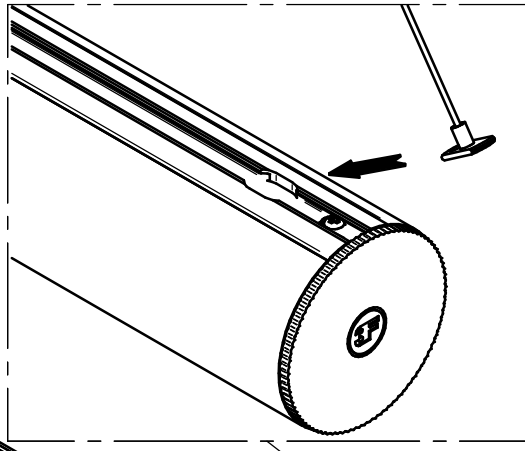

A01650

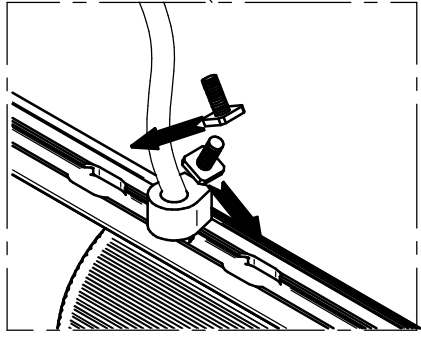

A01647

2/a 2/b

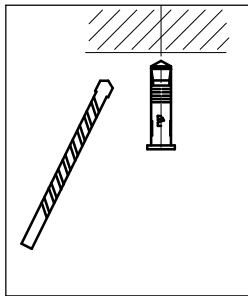

MILLUMINO VL

- L900: A = 240
- L1500: A = 820
- L1800: A = 1120
- L2200: A = 1260
- L2800: A = 1840

MILLUMINO VC

- L1500: A = 540

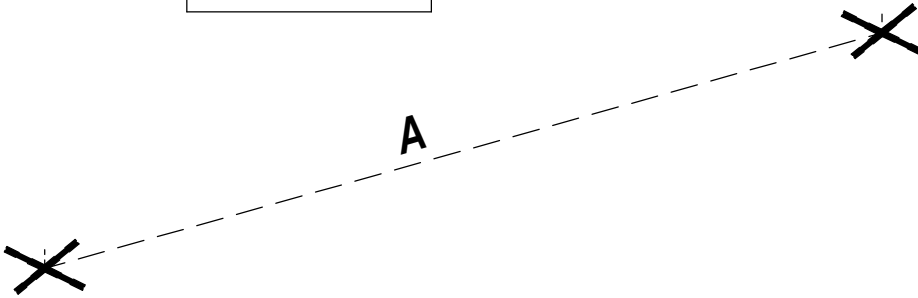

MILLUMINO VL

- L3400: B = 1210

MILLUMINO VC

- L2800: B = 930
- L3400: B = 1220

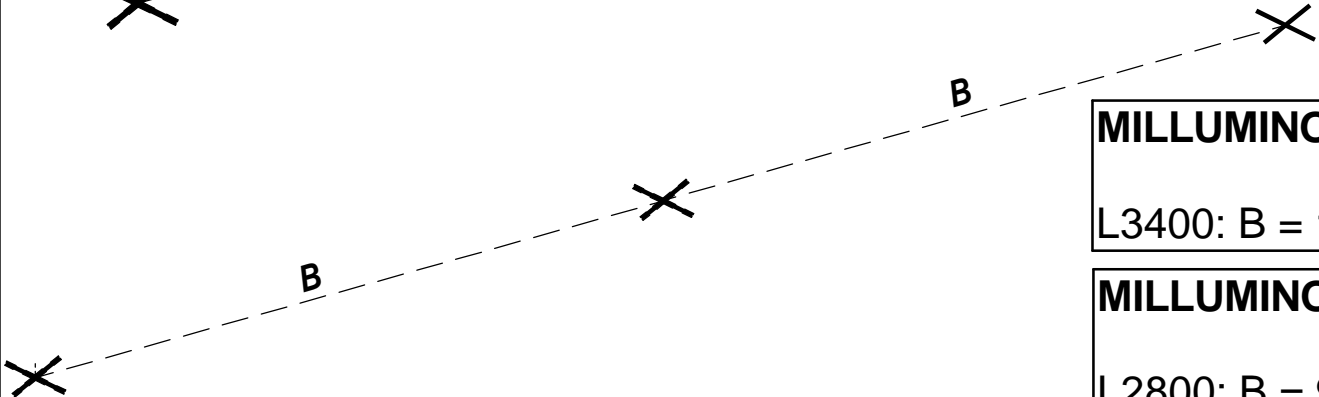

3/a

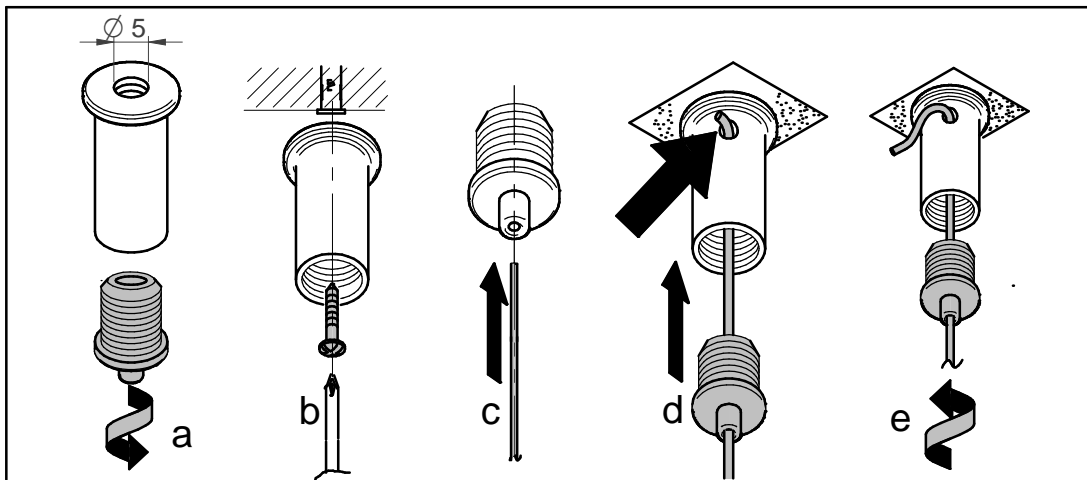

3/b

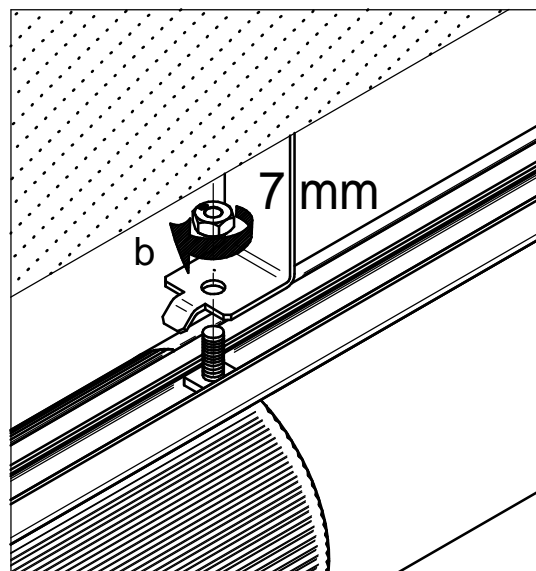
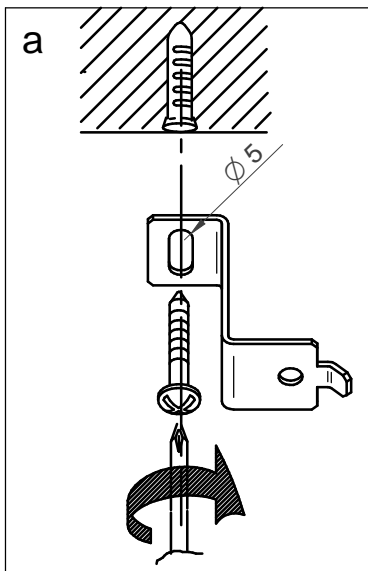

4/a

MILLUMINO VL L: 900,1500,1800

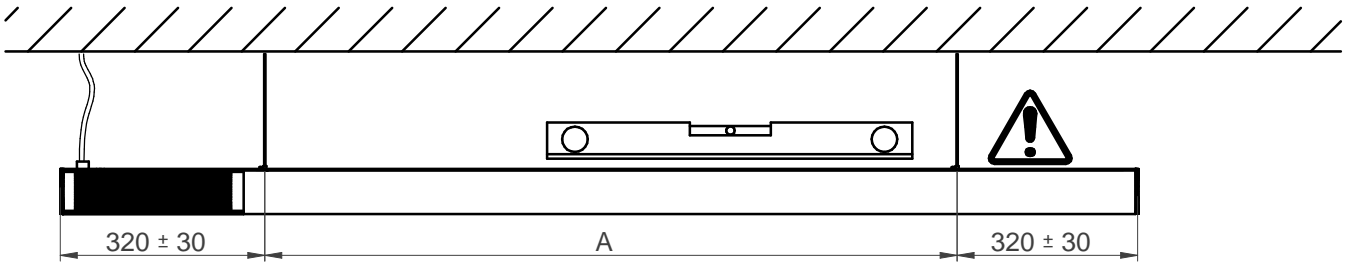

MILLUMINO VL L: 2200, 2800

MILLUMINO VC L: 1500

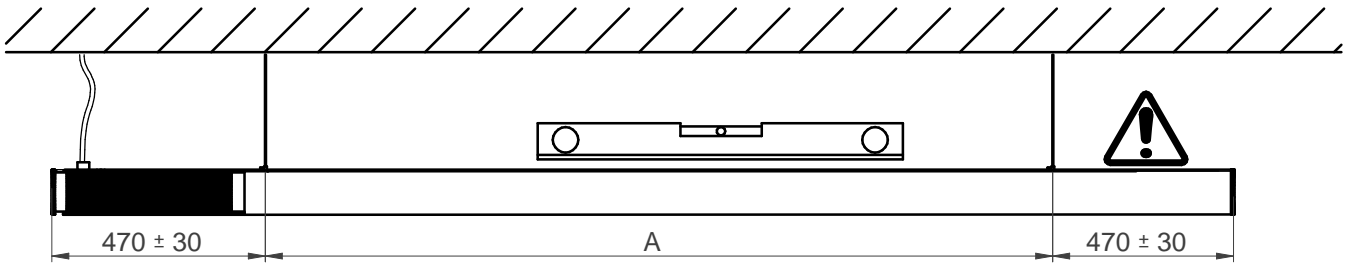

MILLUMINO VL L: 3400

MILLUMINO VC L: 2800, 3400

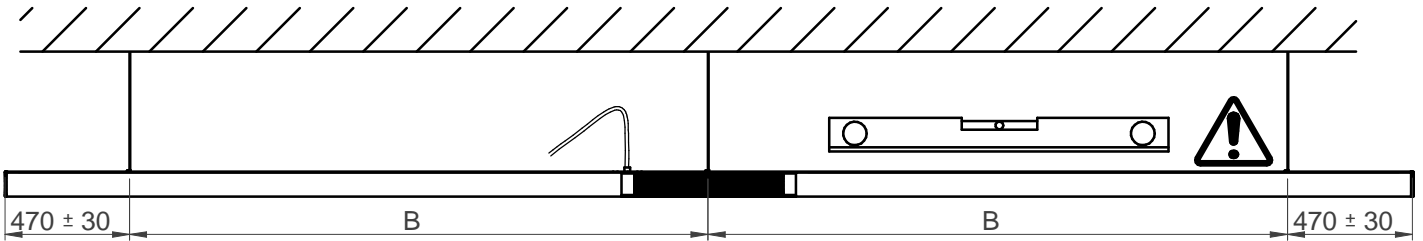

4/b

MILLUMINO VL L: 900,1500,1800

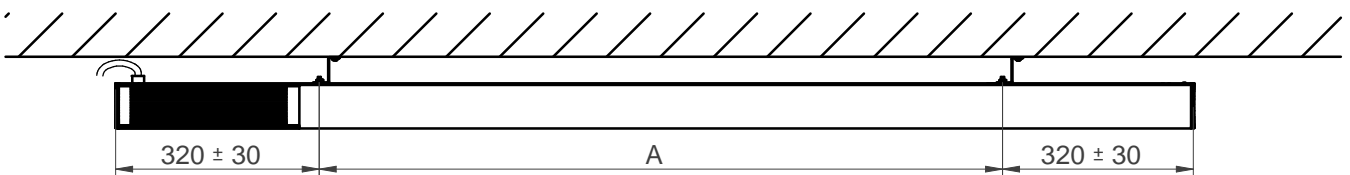

MILLUMINO VL L: 2200, 2800

MILLUMINO VC L: 1500

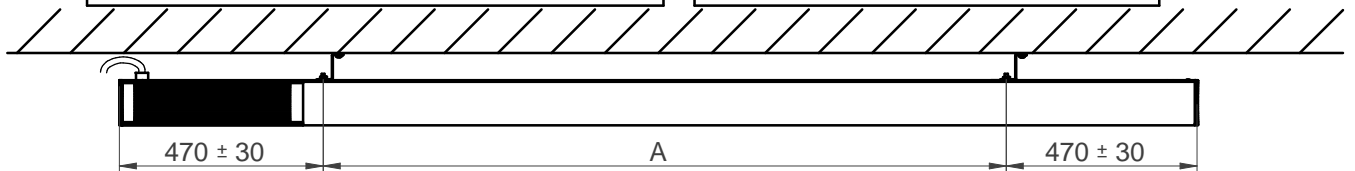

MILLUMINO VL L: 3400

MILLUMINO VC L: 2800, 3400



5/a

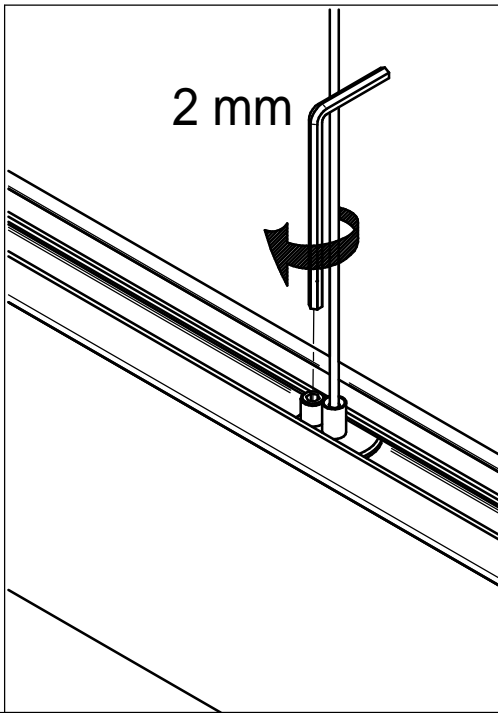

5/b

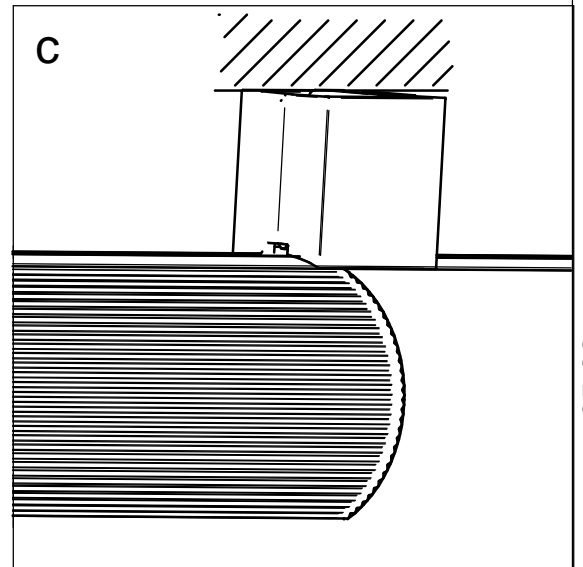
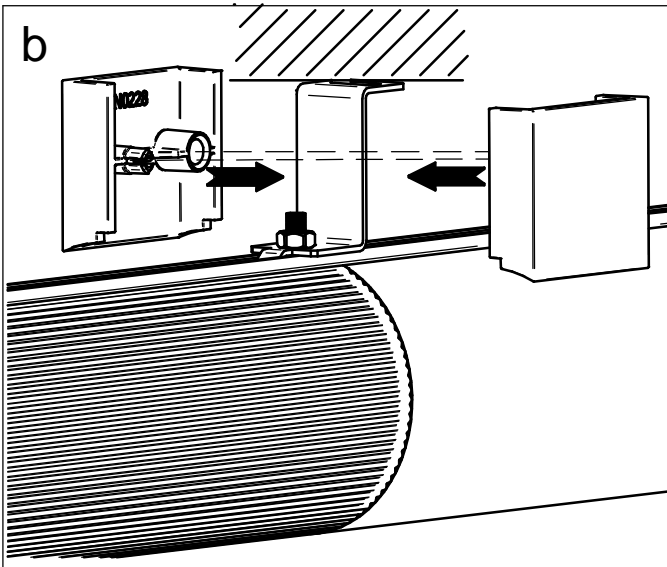
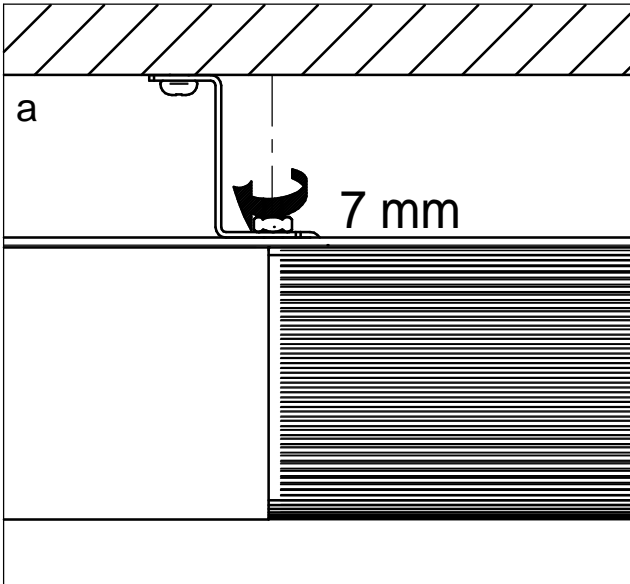

6

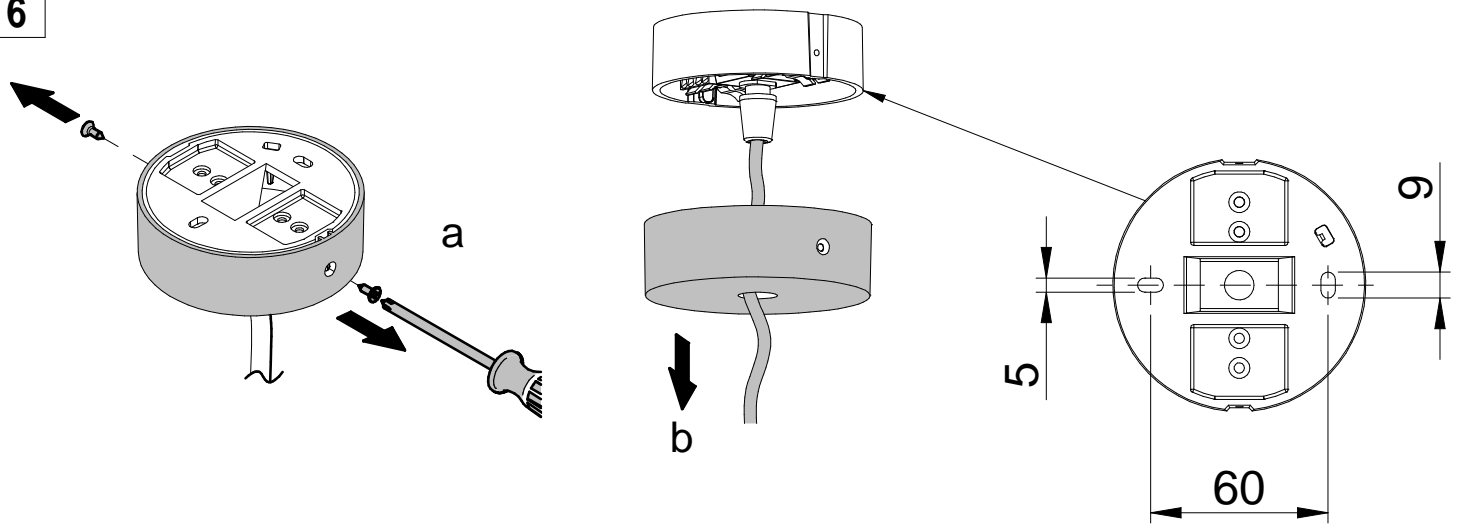

7

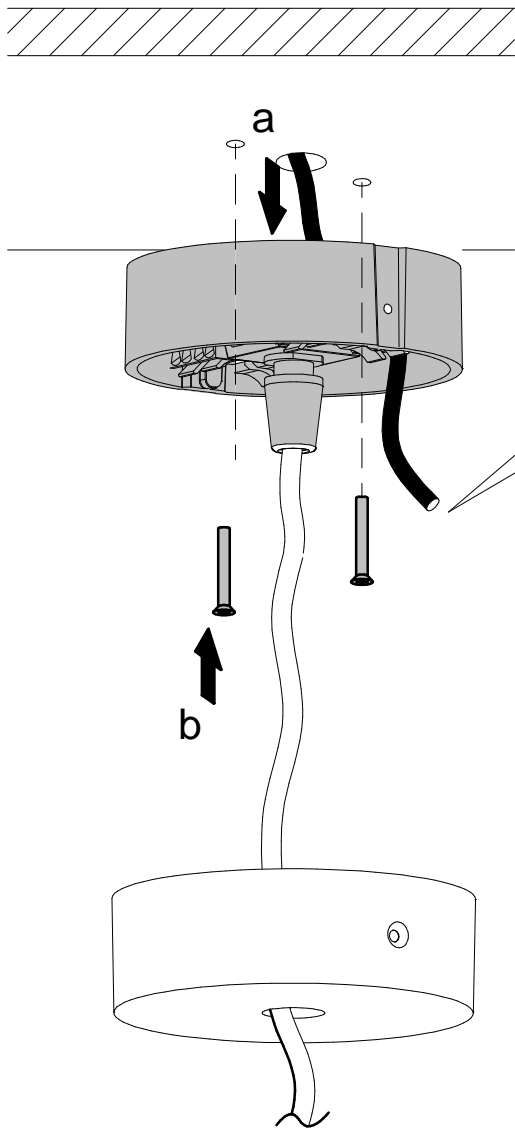

8

DALI

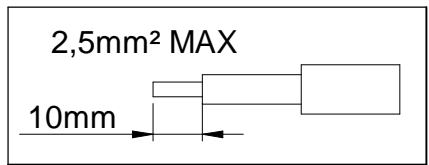

marrone = L
marrón, marron,
brown, braun

azzurro = N
azul, bleu,
blue, blau

rosso = DA+
rojo, rouge,
red, rot

bianco = DA-
blanco, blanc,
white, weiß

verde = 
verde, vert
green, grün

1,5mm²
 Max

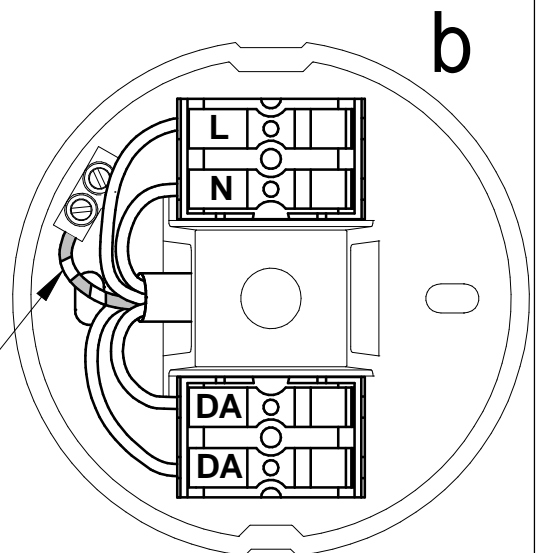
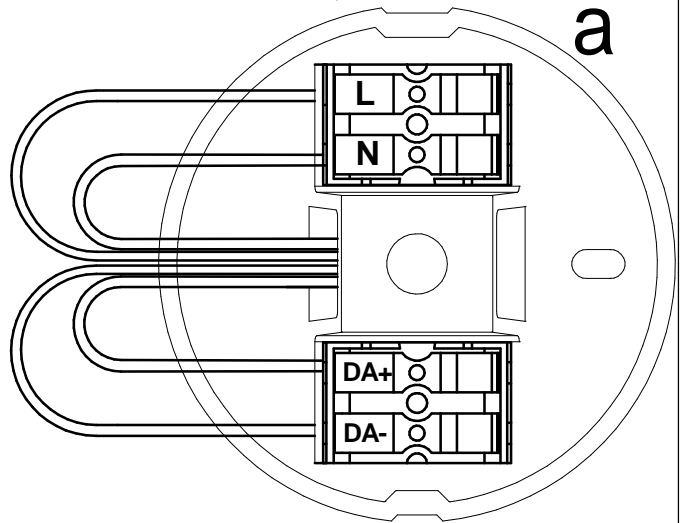
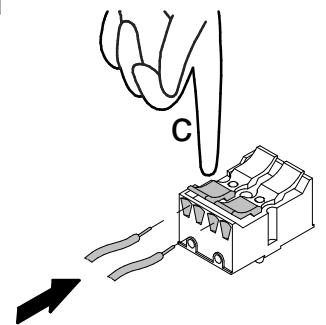
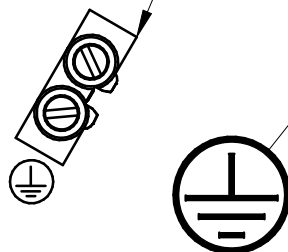

ON / OFF - CASAMBI

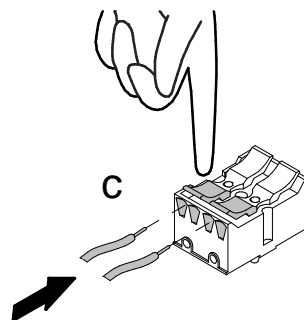
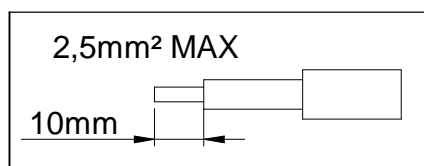

marrone = L
marrón, marron,
brown, braun

azzurro = N
azul, bleu,
blue, blau

verde = 
verde, vert
green, grün

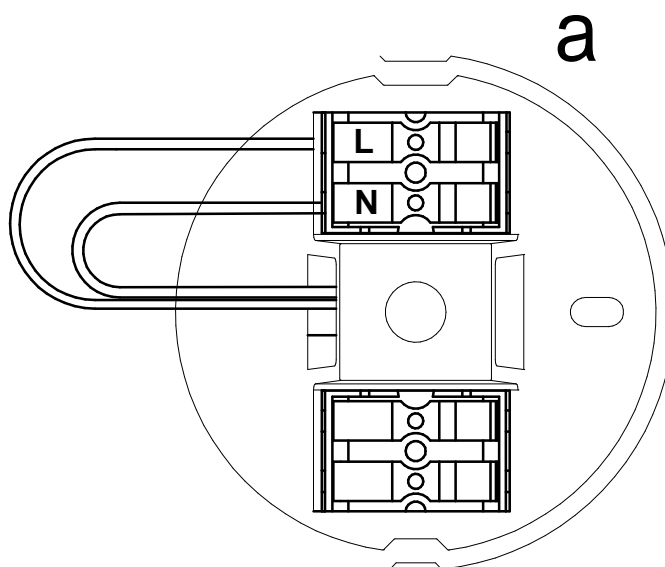

1,5mm²
Max

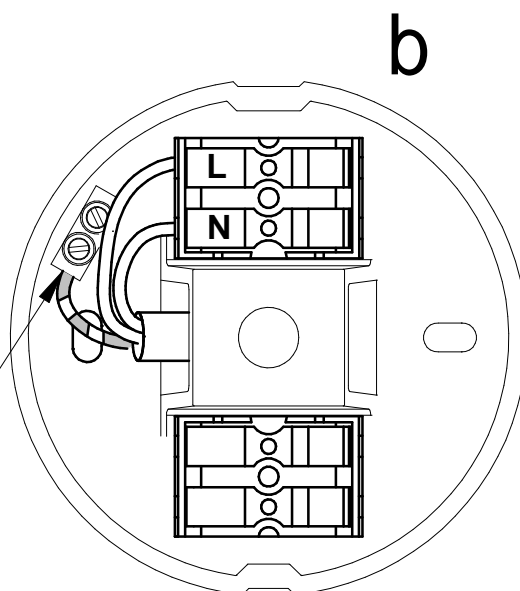
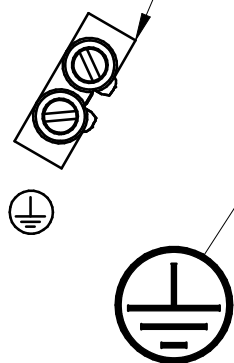



AVVERTENZE

L'apparecchio può essere aperto solo con attrezzi speciali da un elettricista qualificato. Non eseguire la manutenzione dell'apparecchio quando è collegato alla tensione di rete; questo include tassativamente di scollegare il cavo. Non toccare i componenti LED e utilizzare protezioni ESD per evitare danni da scariche elettrostatiche "ai componenti ESD sensibili" durante l'installazione e la manutenzione.
La sorgente luminosa contenuta in questo apparecchio deve essere sostituita solo dal costruttore o dal suo servizio di assistenza o da personale qualificato. Le norme nazionali di installazione devono essere rispettate. Prima di qualsiasi intervento sull'apparecchio disinserire la rete di alimentazione.

WARNINGS

The luminaire can only be opened with special tools by a qualified electrician. Do not service the system when the mains voltage is connected; this includes peremptorily disconnecting the cable. Do not touch the LED components and use ESD protections to prevent damage from Electrostatic Discharge "ESD sensitive components" during installation and maintenance.
The light source contained in this luminaire shall only be replaced by the manufacturer or his assistance service agent or similar qualified person. National installation regulations must be observed. Before any work on the appliance, it must be disconnect from mains.

RECCOMANDATION

Le luminaire peut être ouvert seulement avec des outils spéciaux par un électricien qualifié. Ne jamais intervenir sur le système lorsque la tension d'alimentation est branché, aussi impérativement pour débrancher la câble d'alimentation. Ne pas toucher les composants LED et utiliser une protection ESD pour prévenir les dommages de décharge électrostatique "composants sensibles aux ESD" lors de l'installation et de la maintenance.
La source lumineuse contenue dans ce luminaire ne doit être remplacée que par le fabricant ou par son agent de service ou par une personne également qualifiée. Les règles nationales d'installation doivent être respectées. Avant toute intervention sur l'appareil, il doit être débranché de son alimentation.

ATENCIÓN

Estas Luminarias solo se pueden abrir con herramientas especiales y por un personal cualificado. No realice la manipulación del sistema mientras esté conectado a la red, incluso obligatoriamente la desconexión del cable.
Durante las instalación y el mantenimiento No toque los componentes LED y use protección especial ESD para evitar descargas electroestáticas de los componentes sensibles a descargas electroestáticas.
La fuente de iluminación contenida en esta luminaria solo debe ser reemplazada por el fabricante o por su agente igualmente calificada. Se deben respetar las normas nacionales de instalación. Antes de realizar cualquier trabajo en el aparato, debe desconectarse de la red eléctrica.

ACHTUNG !

Die Leuchten können nur mit einem Spezialwerkzeug durch einen Elektrofachmann geöffnet werden. Führen Sie keine Wartungsarbeiten unter Netzspannung durch, dies schliesst eine Netztrennung mechanisch/elektrisch der Leuchtenzuleitung ein. (VDE 0100) Berühren Sie nicht die LED-Komponenten während der Installation und Wartung. Benutzen Sie einen ESD-Schutz um eine Beschädigung durch elektrostatische Entladung zu verhindern.
Die in dieser Leuchte enthaltene Lichtquelle darf nur vom Hersteller oder seinem Servicemitarbeiter oder einer ähnlich qualifizierten Person ausgetauscht werden. Die nationalen Installationsvorschriften sind zu beachten. Vor jeder Arbeit an der Leuchte ist diese vom Netz zu trennen.



- ATTENZIONE : Non toccare i moduli Led - Maneggiare con cautela
- Dispositivo sensibile alle scariche elettrostatiche - Usare guanti antistatici
- Non esporre i moduli LED a polveri e/o a sostanze chimicamente aggressive quali Cloro, Zolfo, Ammoniaca, Oli Minerali, ioni bisolfite, ecc.
- ATTENTION : Ne touchez pas les modules Led - Manipuler avec précaution
- Dispositif sensible aux décharges électrostatiques - Utiliser gants antistatiques
- N'exposez pas les modules LED aux poudres et / ou aux substances chimiquement agressives telles que le chlore, le soufre, l'ammoniac, les huiles minérales, ion bisulfite, etc.

- ATENCION : No toque los módulos Led - Tratar con cuidado
- Dispositivo sensible a las descargas electroestáticas - Use guantes antiestáticos
- No exponga los módulos LED a polvos y / o sustancias químicamente agresivas como cloro, azufre, amoníaco, aceites minerales, ion bisulfite, etc.

- ATTENTION : Do not touch the Led modules - Observe precautions for handling
- Device sensitive to electrostatic discharge - Use antistatic gloves
- Do not expose LED modules to powders and / or chemically aggressive substances such as Chlorine, Sulfur, Ammonia, Mineral Oils, bisulfite ion, etc.
- ACHTUNG : Berühren Sie nicht die LED-Module - Beachten Sie die Vorsichtsmaßnahmen für die Handhabung - Gerät empfindlich gegen elektrostatische Entladung - Verwenden Sie antistatische Handschuhe.
- Setzen Sie LED-Module keinen Pulvern und / oder chemisch aggressiven Substanzen wie Chlor, Schwefel, Ammoniak, Mineralölen usw, bisulfite-ion, aus.

L'apparecchio non deve essere smaltito come rifiuto urbano, mediante cassonetto, ma e' soggetto a raccolta separata.
Il mancato rispetto di questa norma e' sanzionato dalla legge e potrebbe provocare potenzialmente effetti negativi sia per l'ambiente sia sulla salute umana.

The luminaire must not be eliminated as urban waste, by means of refuse body, rather it is object of separate collection.
The non-observance of this rule is sanctioned by the law and potentially could cause negative effects both on the environment and on human health.

L'appareil ne doit pas être éliminé comme ordures ménagères, dans la poubelle, mais il est sujet à collecte sélective.
La non-observation de cette disposition est sanctionnée par la loi et peut provoquer en puissance effets négatifs soit pour l'ambiance soit pour la santé humaine.



Die Leuchte muss als Sondermüll entsorgt werden!
Die Nichteinhaltung dieser Bestimmung kann strafrechtlich verfolgt werden.
Ferner verursacht eine nicht gerechte Entsorgung negative Folgen für die Umwelt und die menschliche Gesundheit.

La luminaria no debe ser desechada como residuo urbano, sino a través de un gestor de residuos, ya que es objeto de recogida selectiva.
El incumplimiento de esta norma está sancionado por la ley y puede causar potencialmente daños tanto al medio ambiente como a la salud.

DECRETO LEGISLATIVO 14 marzo 2014, n. 49. Attuazione della direttiva 2012/19/UE (Revisione della Direttiva 2002/96/UE).



Sorgente luminosa (solo LED) sostituibile da un professionista
Replaceable (LED only) light source by a professional
Source lumineuse (LED uniquement) remplaçable par un professionnel
Fuente luminosa reemplazable (solo LED) por un profesional
Austauschbare (nur LED) Lichtquelle durch einen Fachmann

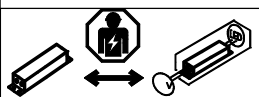

Alimentatore sostituibile da un professionista
Replaceable control gear by a professional
Boîtier de commande remplaçable par un professionnel
Equipo de control reemplazable por un profesional
Austauschbare Vorschaltgeräte durch einen Fachmann

This product contains a light source of energy efficiency class < <https://www.3f-filippi.com/en/Search> >
Questo prodotto contiene una sorgente luminosa di classe di efficienza energetica < <https://www.3f-filippi.com/it/Ricerca> >
Ce produit contient une source lumineuse de classe d'efficacité énergétique < <https://www.3f-filippi.com/fr/Recherche> >
Dieses Produkt enthält eine Lichtquelle der Energieeffizienzklasse < <https://www.3f-filippi.com/de/Suche> >
Este producto contiene una fuente de luz de clase de eficiencia energética < <https://www.3f-filippi.com/es/Busqueda> >

To reduce the risk of strangulation, the flexible wiring connected to this luminaire shall be effectively fixed to the wall if the wiring is within arm's reach.
Per ridurre il rischio di strangolamento, il cavo flessibile collegato all'apparecchio deve essere efficacemente fissato alla parete, se si trova all'interno del volume di accessibilità.
Um die Strangulationsgefahr zu verringern, muss das flexible Kabel, das an der Leuchte angeschlossen ist, wirksam an der Wand befestigt werden, wenn es sich innerhalb der Reichweite befindet.
Pour réduire le risque de strangulation, le câble flexible relié à l'appareil doit être efficacement fixé au mur s'il est à portée de main.
Para reducir el riesgo de estrangulamiento, el cableado flexible conectado a esta luminaria debe estar fijado de manera eficaz a la pared si el cableado está al alcance de la mano.