

CE EN IEC 60598-1 IEC/TR 62778:2014 IEC/EN 60598-2-22 "eme.3F-Filippi.com" 650°C 0.2J IK02 IP40

This product contains a light source of energy efficiency class < <https://www.3f-filippi.com/en/Search> >
Questo prodotto contiene una sorgente luminosa di classe di efficienza energetica < <https://www.3f-filippi.com/it/Ricerca> >
Ce produit contient une source lumineuse de classe d'efficacité énergétique < <https://www.3f-filippi.com/fr/Recherche> >
Dieses Produkt enthält eine Lichtquelle der Energieeffizienzklasse < <https://www.3f-filippi.com/de/Suche> >
Este producto contiene una fuente de luz de clase de eficiencia energética < <https://www.3f-filippi.com/es/Busqueda> >

DRIVER/LED : NO SELV

* - a richiesta
- sur demande
- bajo pedido
- on request
- auf Anfrage

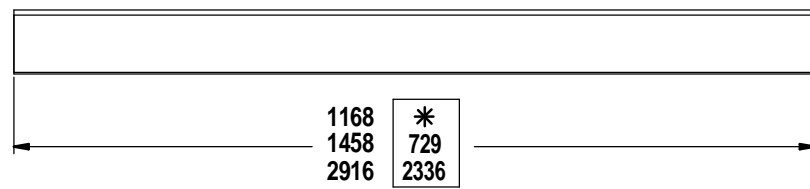
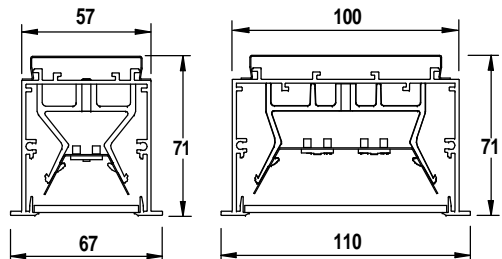

Sorgente luminosa (solo LED) sostituibile da un professionista
Replaceable (LED only) light source by a professional
Source lumineuse (LED uniquement) remplaçable par un professionnel
Fuente luminosa reemplazable (solo LED) por un profesional
Austauschbare (nur LED) Lichtquelle durch einen Fachmann

Alimentatore sostituibile da un professionista
Replaceable control gear by a professional
Boîtier de commande remplaçable par un professionnel
Equipo de control reemplazable por un profesional
Austauschbare Vorschaltgeräte durch einen Fachmann

- ATTENZIONE : Non toccare i moduli Led - Maneggiare con cautela
Dispositivo sensibile alle scariche elettrostatiche - Usare guanti antistatici
Non esporre i moduli LED a polveri e/o sostanze chimicamente aggressive quali Cloro, Zolfo, Ammoniaca, Oli Minerali, ecc.
- ATTENTION : Ne touchez pas les modules Led - Manipuler avec précaution
Dispositif sensible aux décharges électrostatiques - Utiliser gants antistatiques
N'exposez pas les modules LED aux poussières et/ou aux produits chimiques agressifs comme chlore, soufre, ammoniac, huiles minérales, etc.
- ATENCION : No toque los módulos Led - Tratar con cuidado
Dispositivo sensible a las descargas electrostáticas - Use guantes antiestáticos
No exponga los módulos LED a polvos y/o sustancias químicamente agresivas como cloro, azufre, amoníaco, aceites minerales, etc.

- ATTENTION : Do not touch the Led modules - Observe precautions for handling
Device sensitive to electrostatic discharge - Use antistatic gloves
Do not expose LED modules to dust and/or chemically aggressive substances such as Chlorine, Sulphur, Ammonia, Mineral Oils, etc.
- ACHTUNG : LED-module nicht berühren - mit Vorsicht behandeln
Gerät empfindlich gegen elektrostatische Entladung - Verwenden Sie antistatische Handschuhe
Setzen Sie die LED-Module keinen Staubpartikeln und/oder aggressiven chemischen Substanzen wie Chlor, Schwefel, Ammoniak, Mineralölen usw. aus.

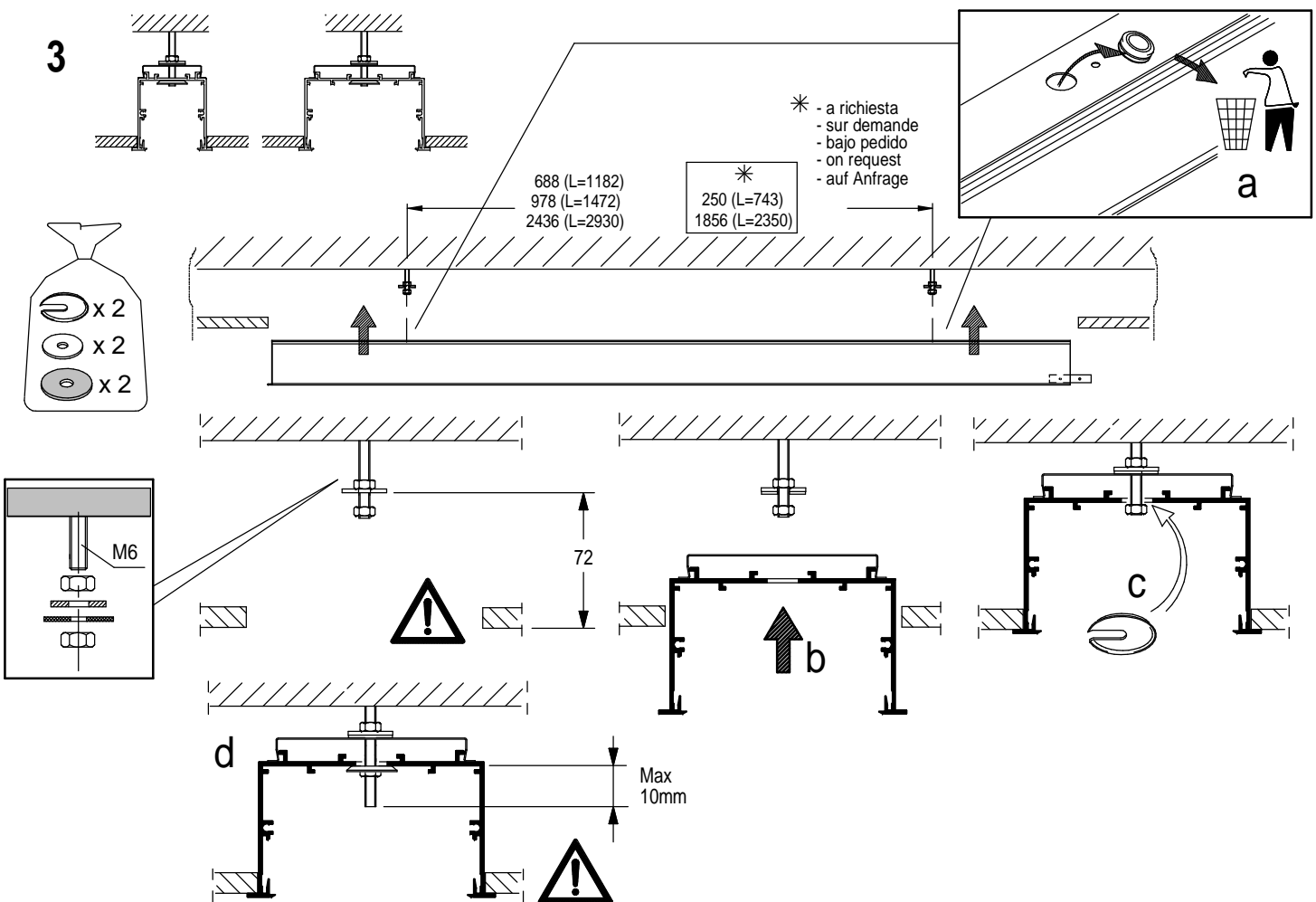
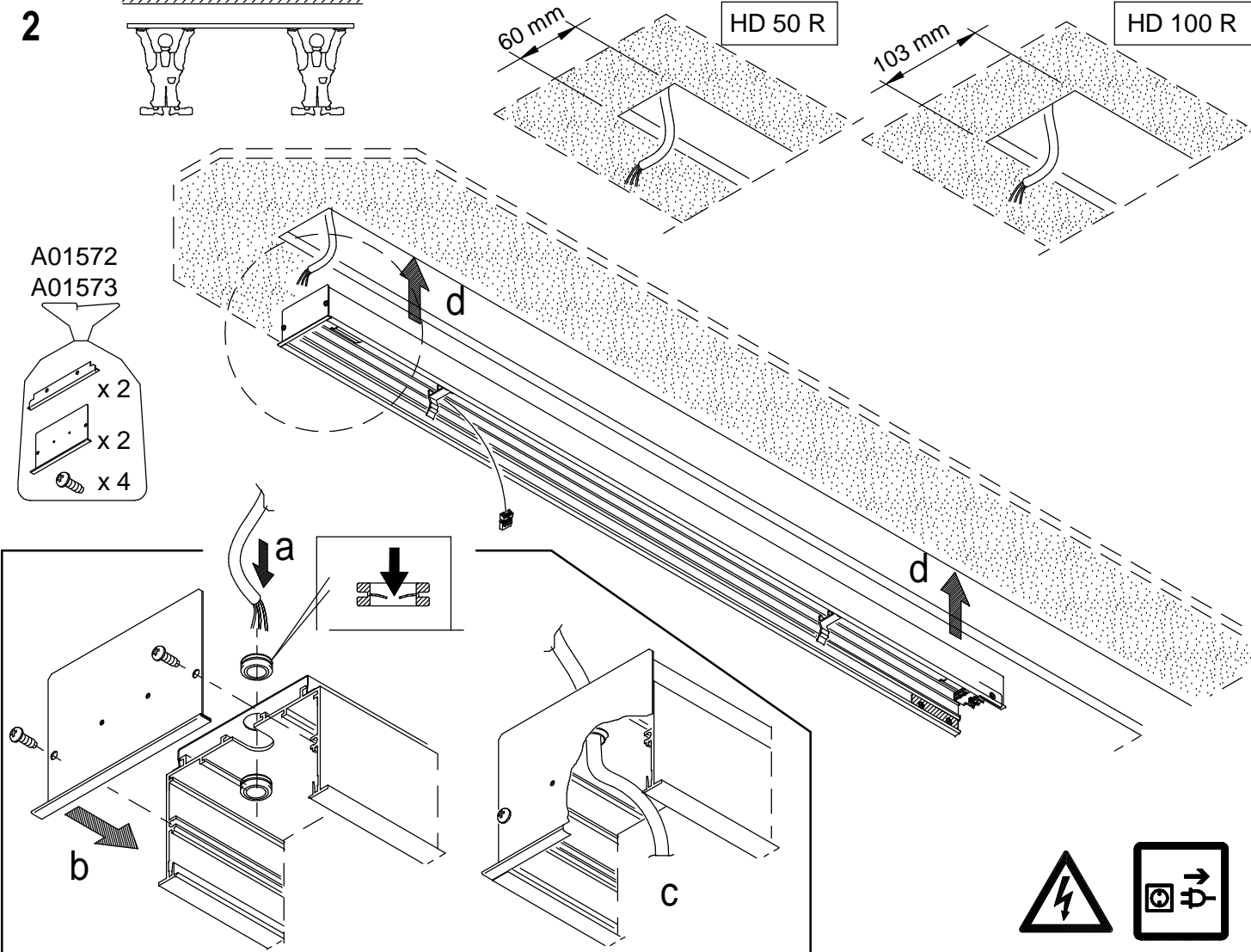
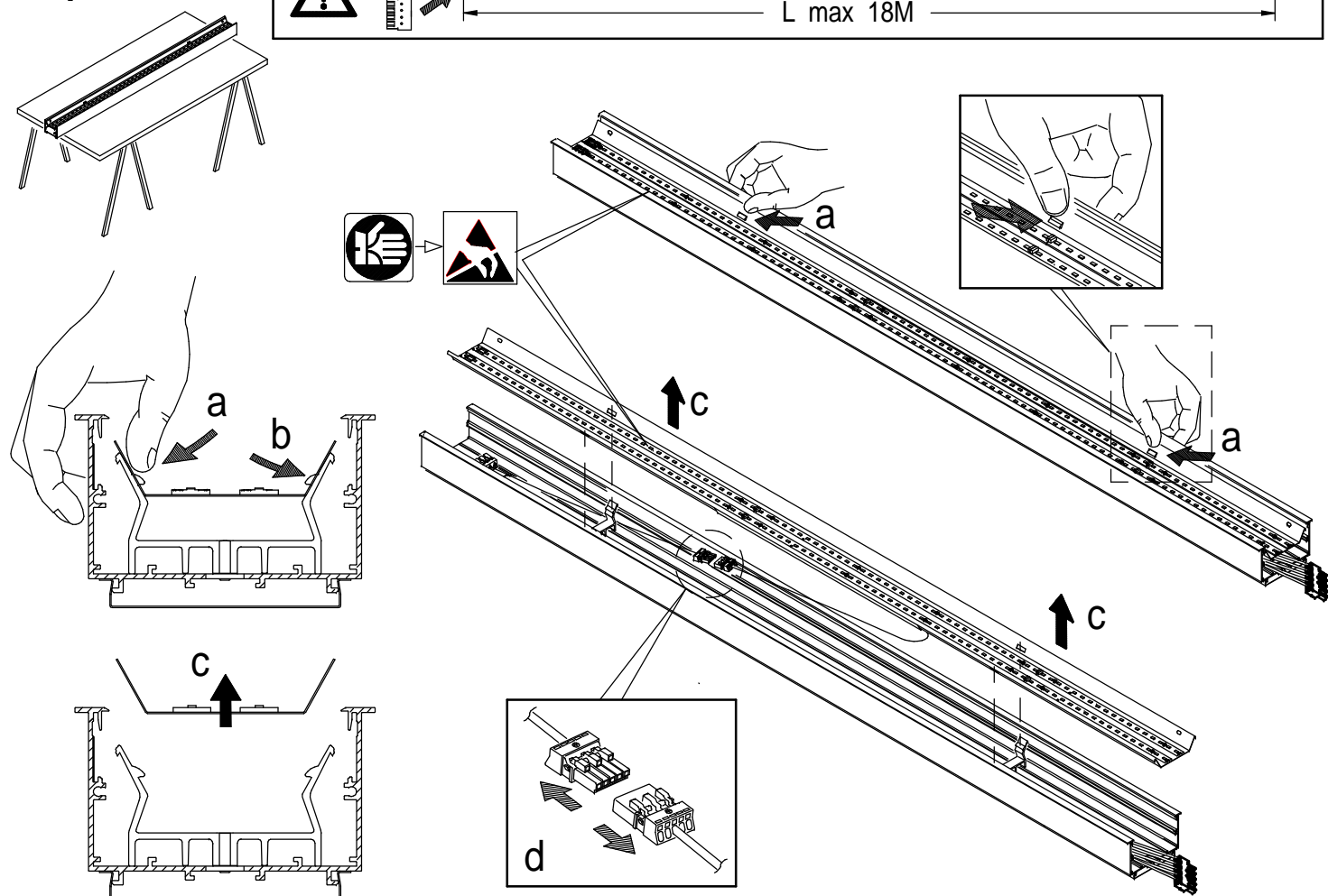
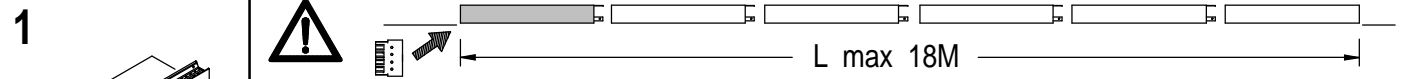

3/A

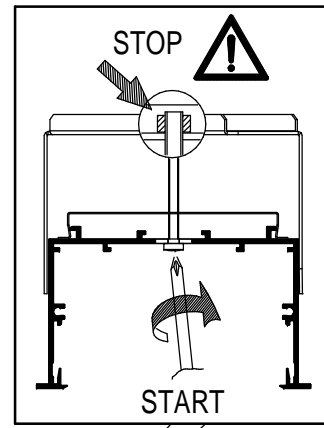
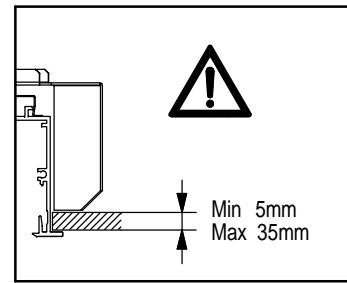
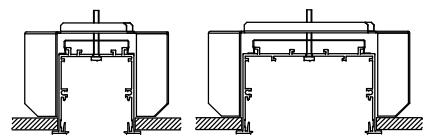

A01565
A01566

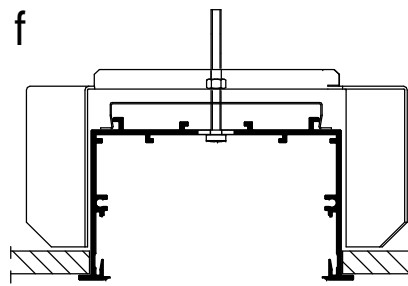
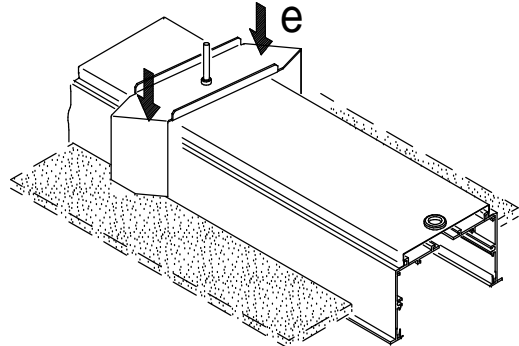
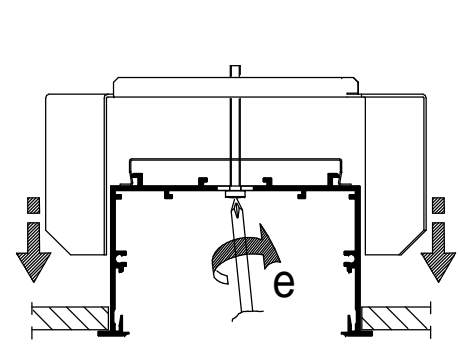
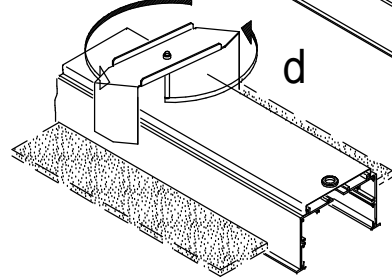
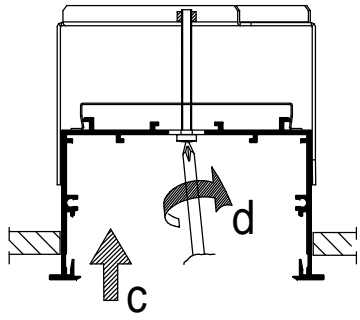
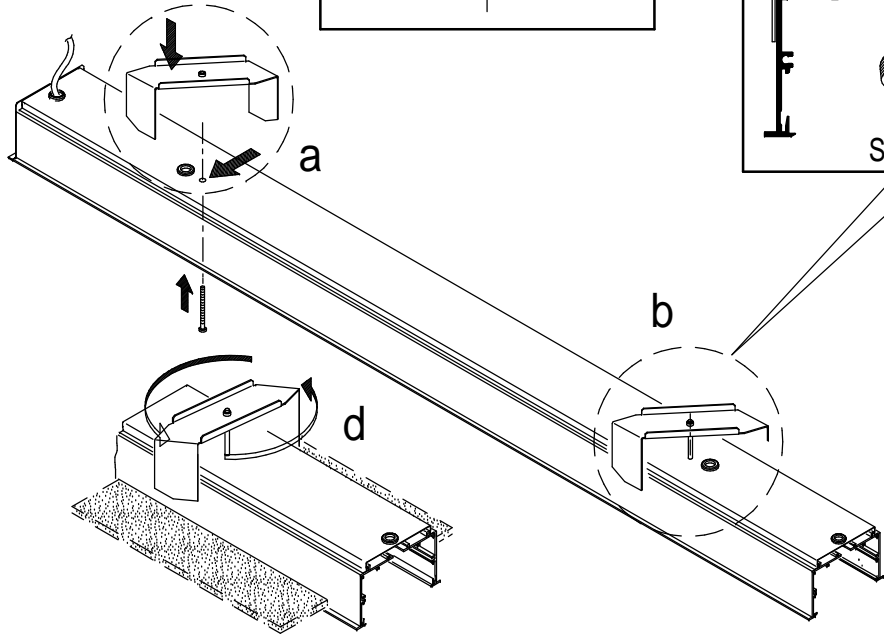
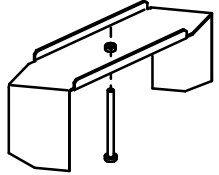

4

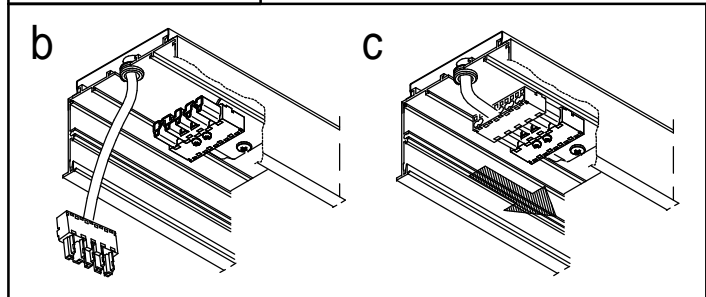
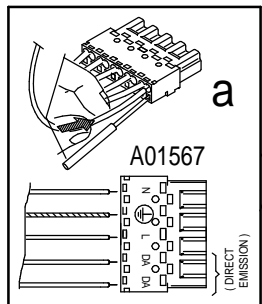
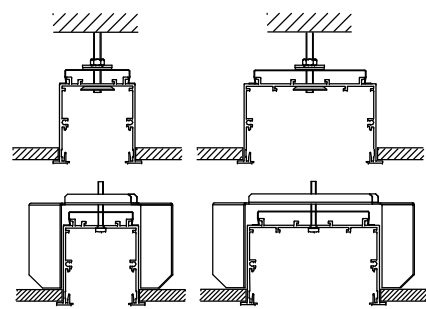

5

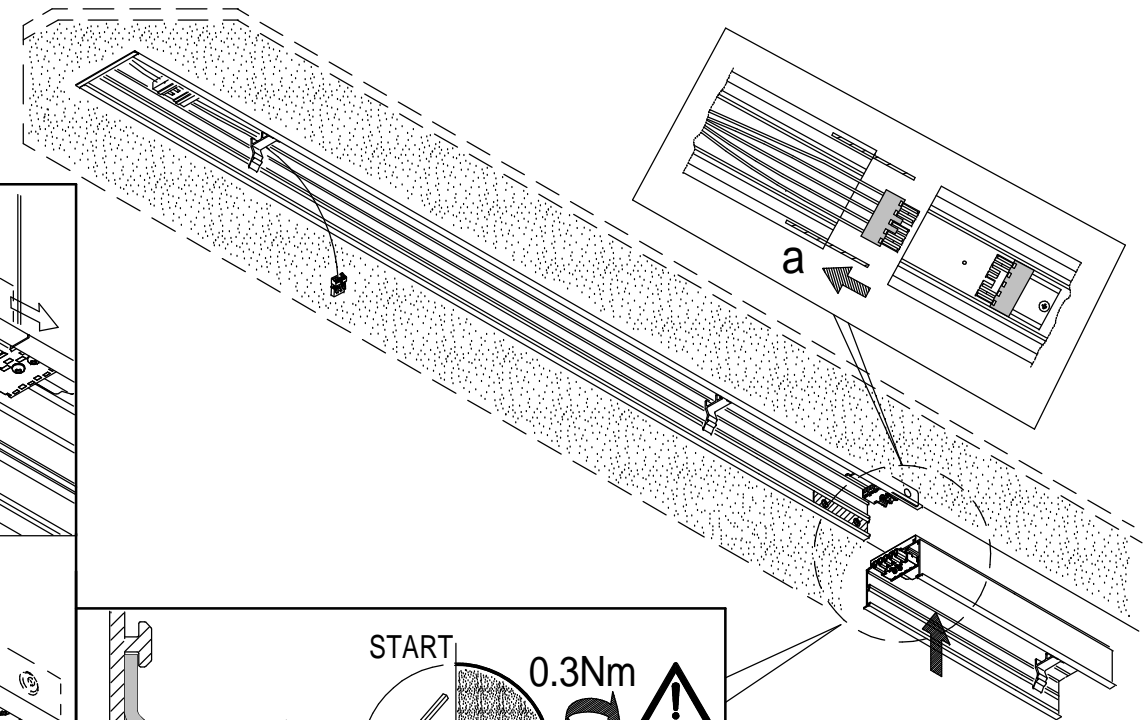
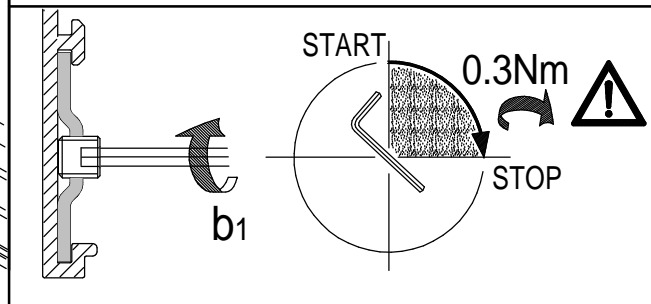
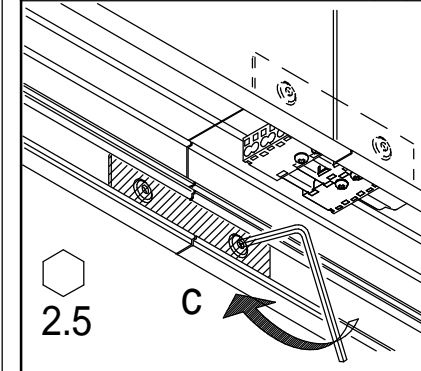
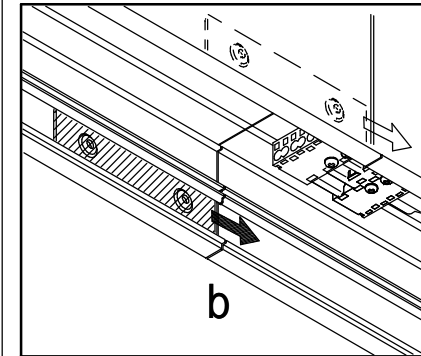
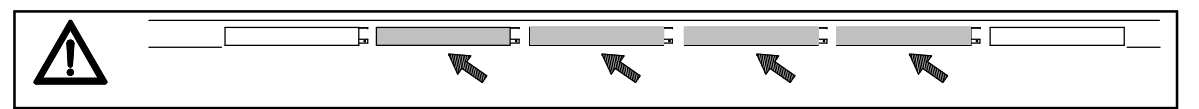

6

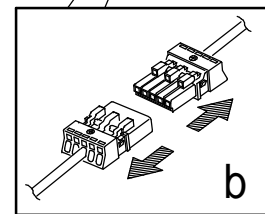
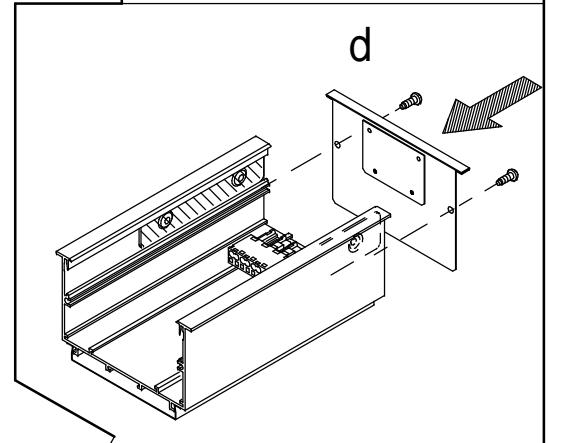
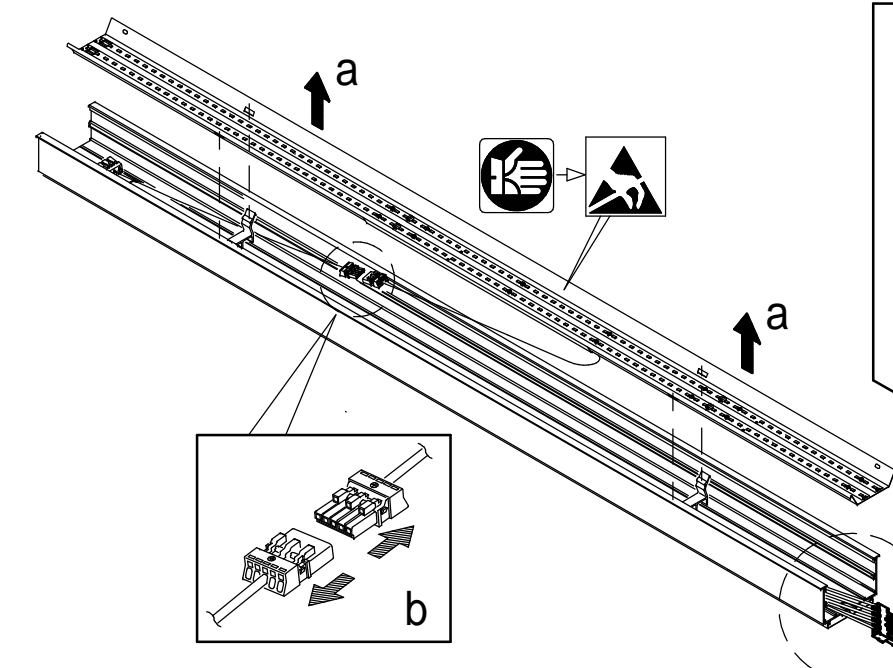
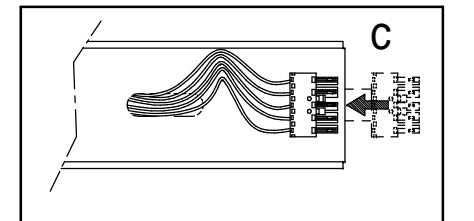
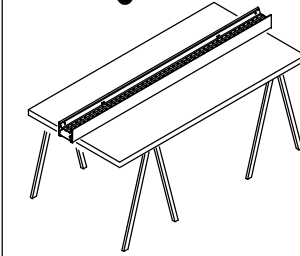
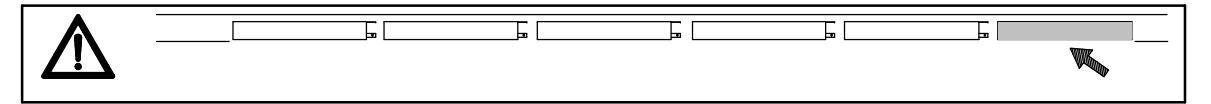

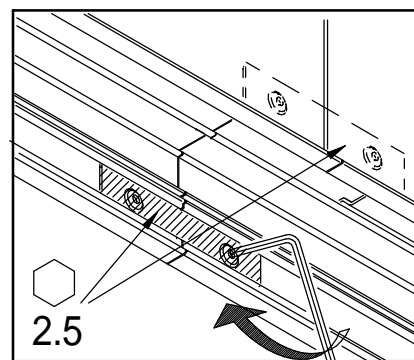
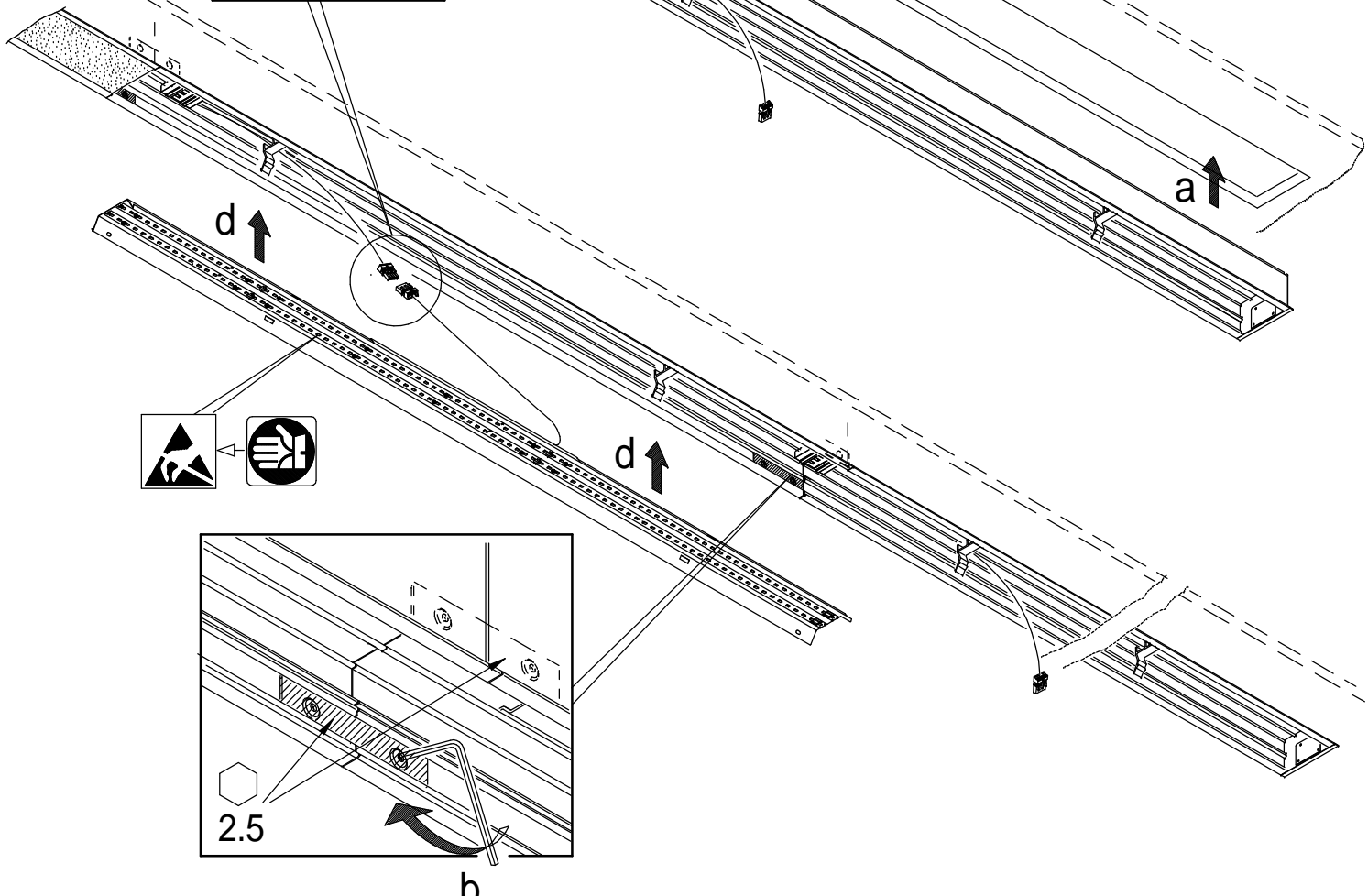
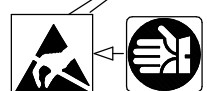
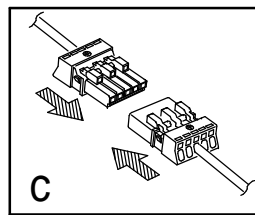
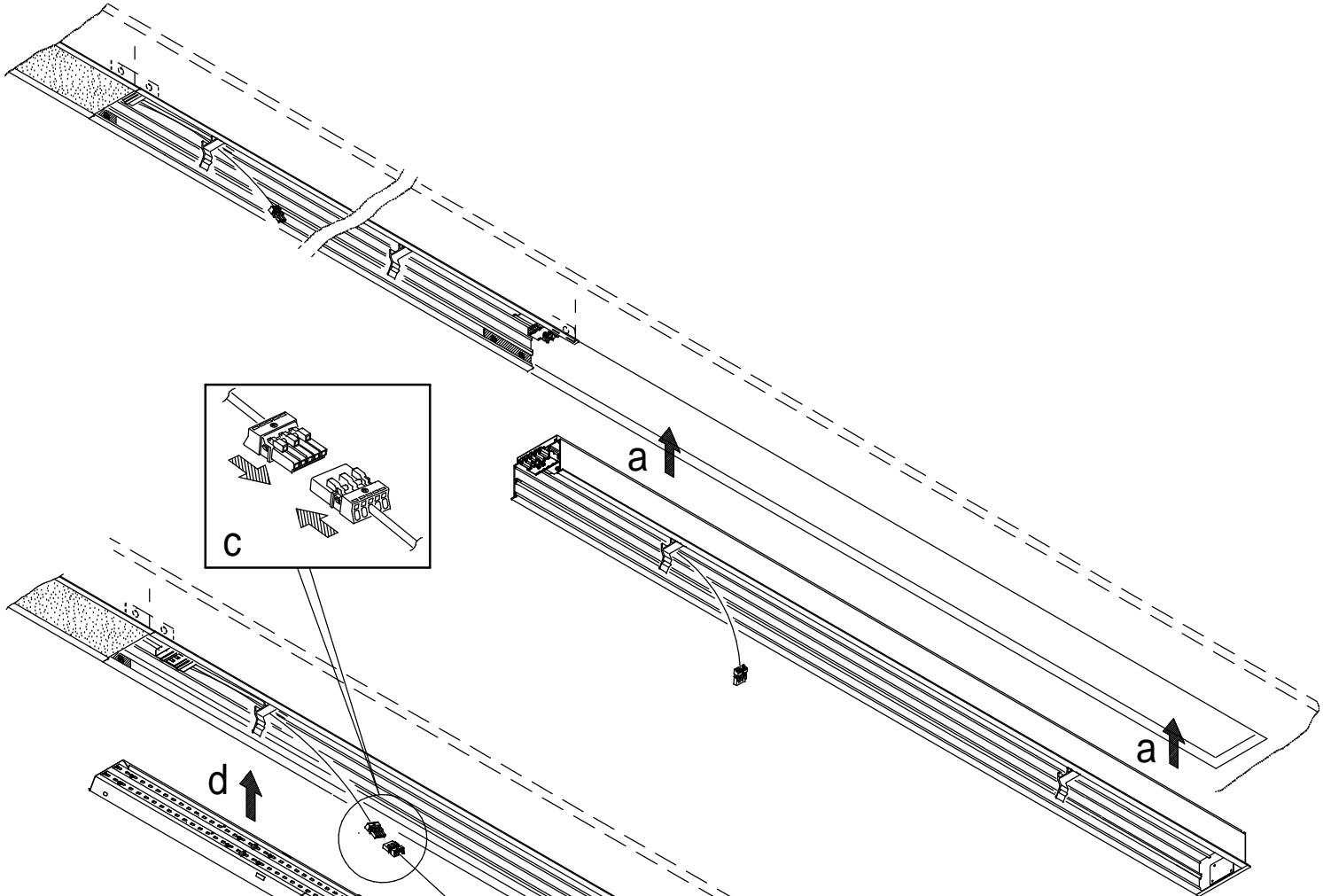
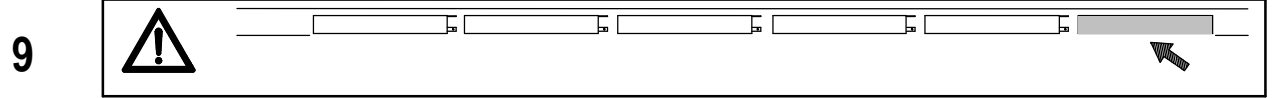
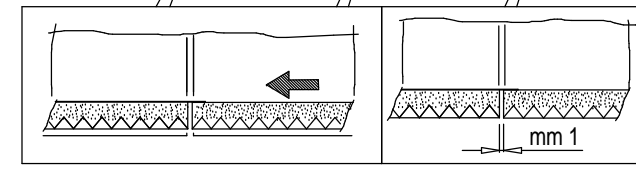
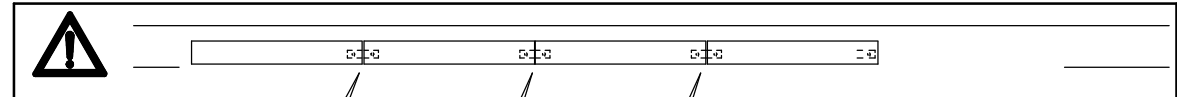
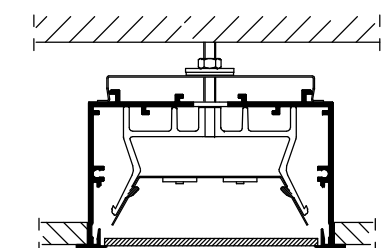
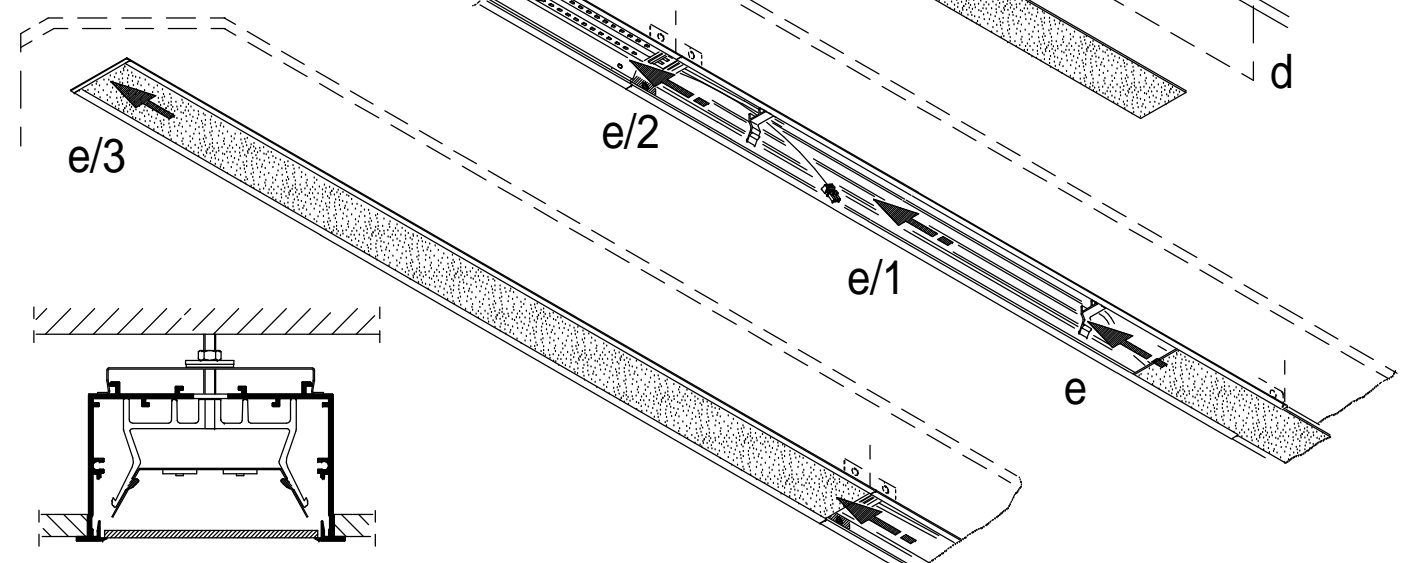
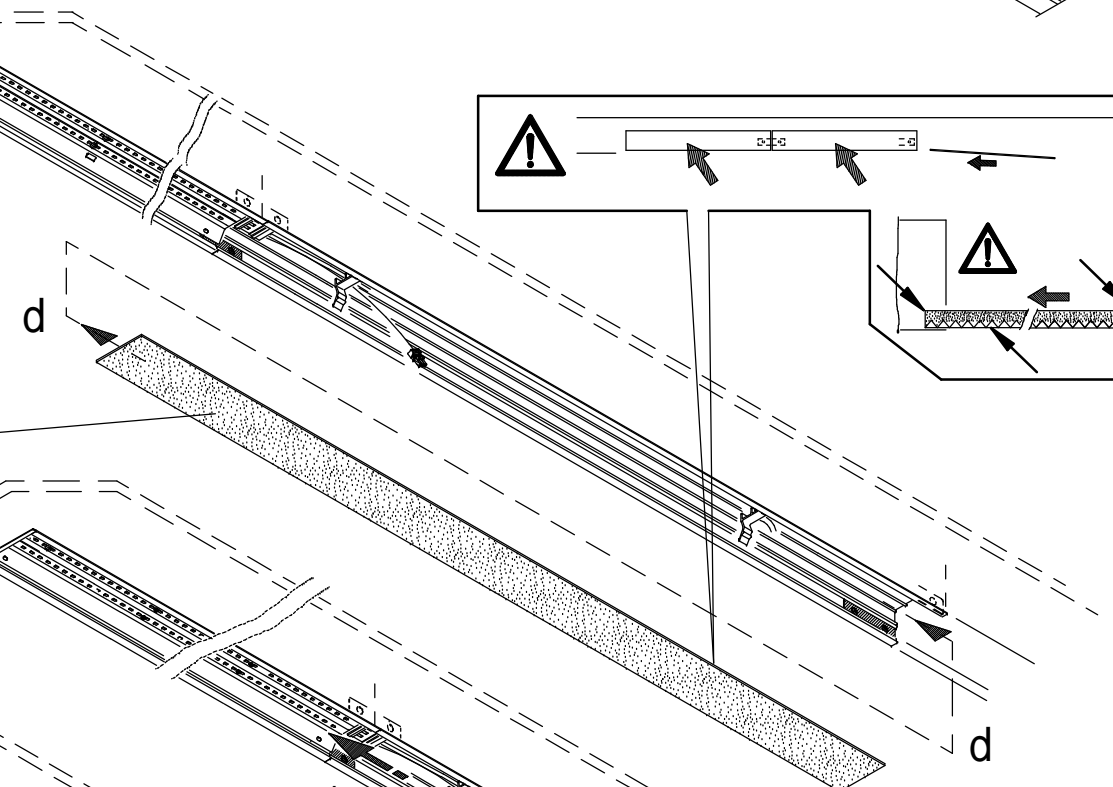
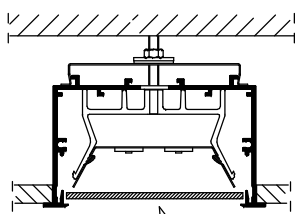
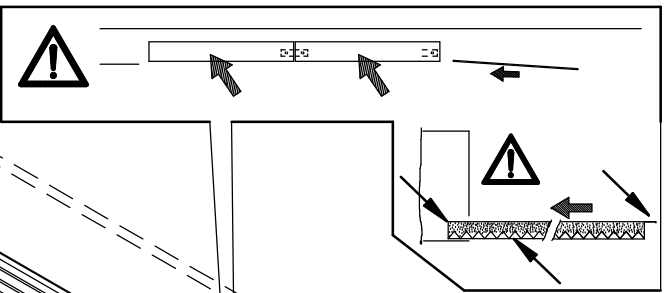
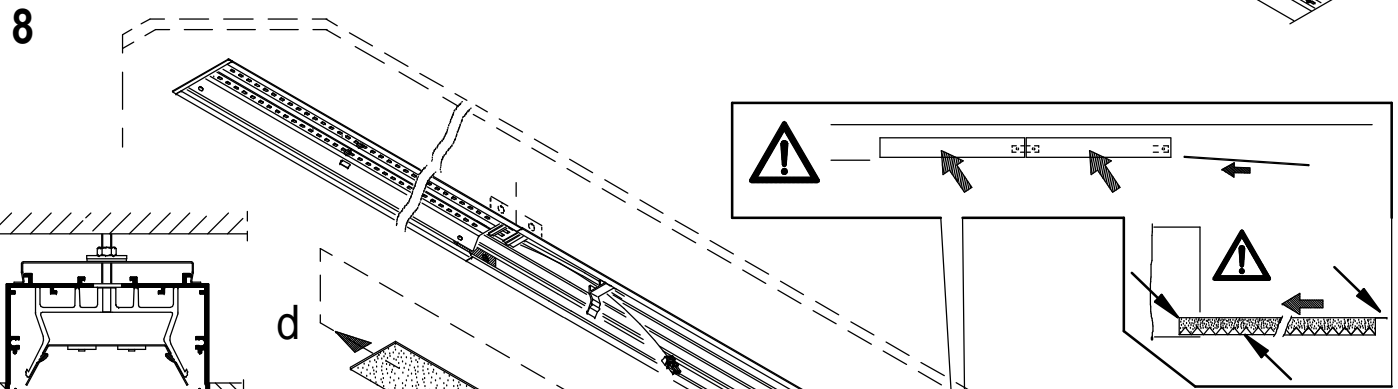
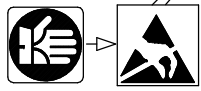
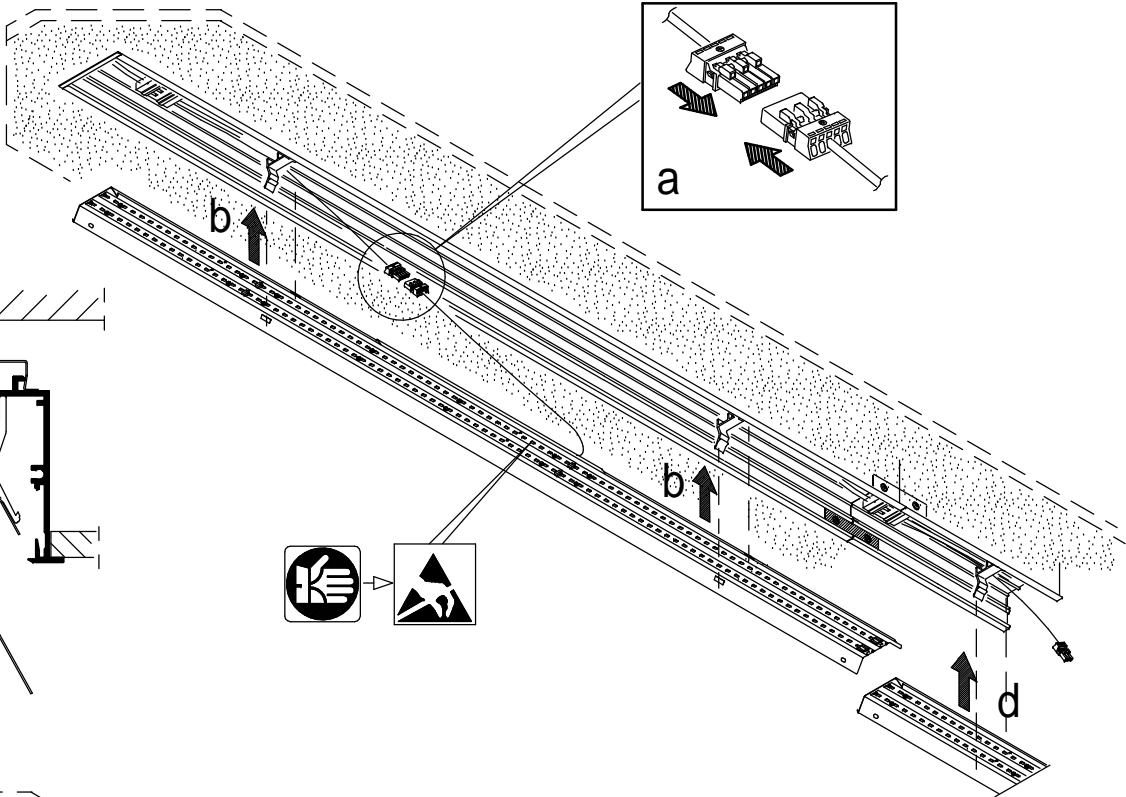
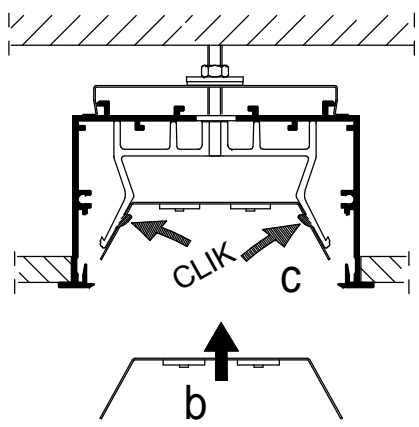
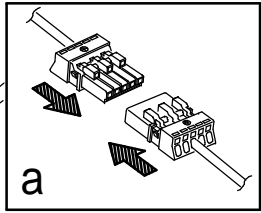
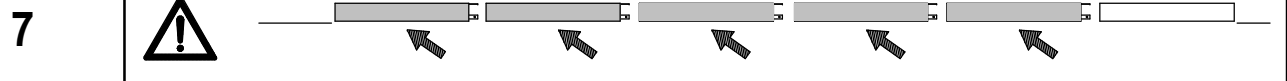

10

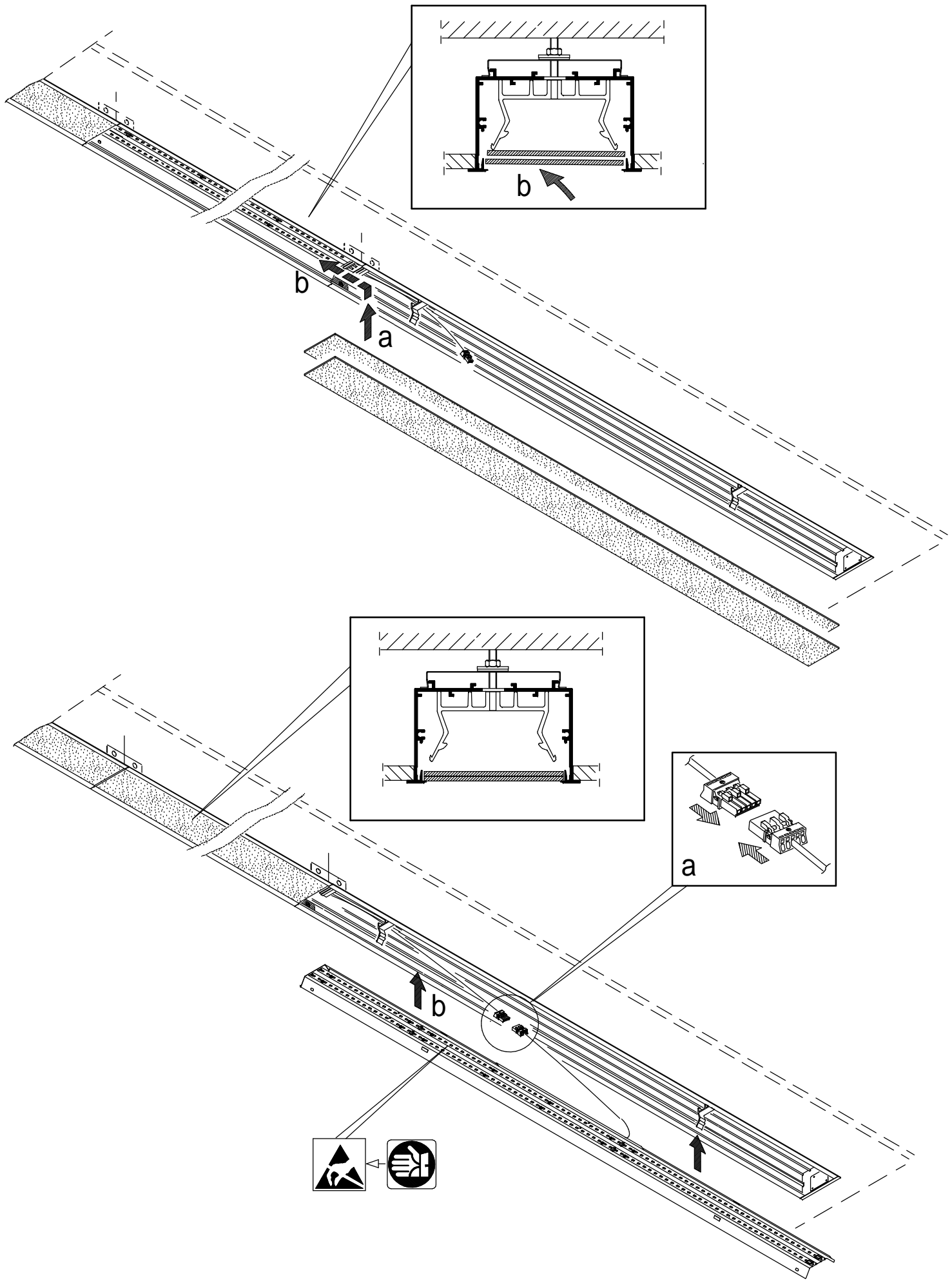

11

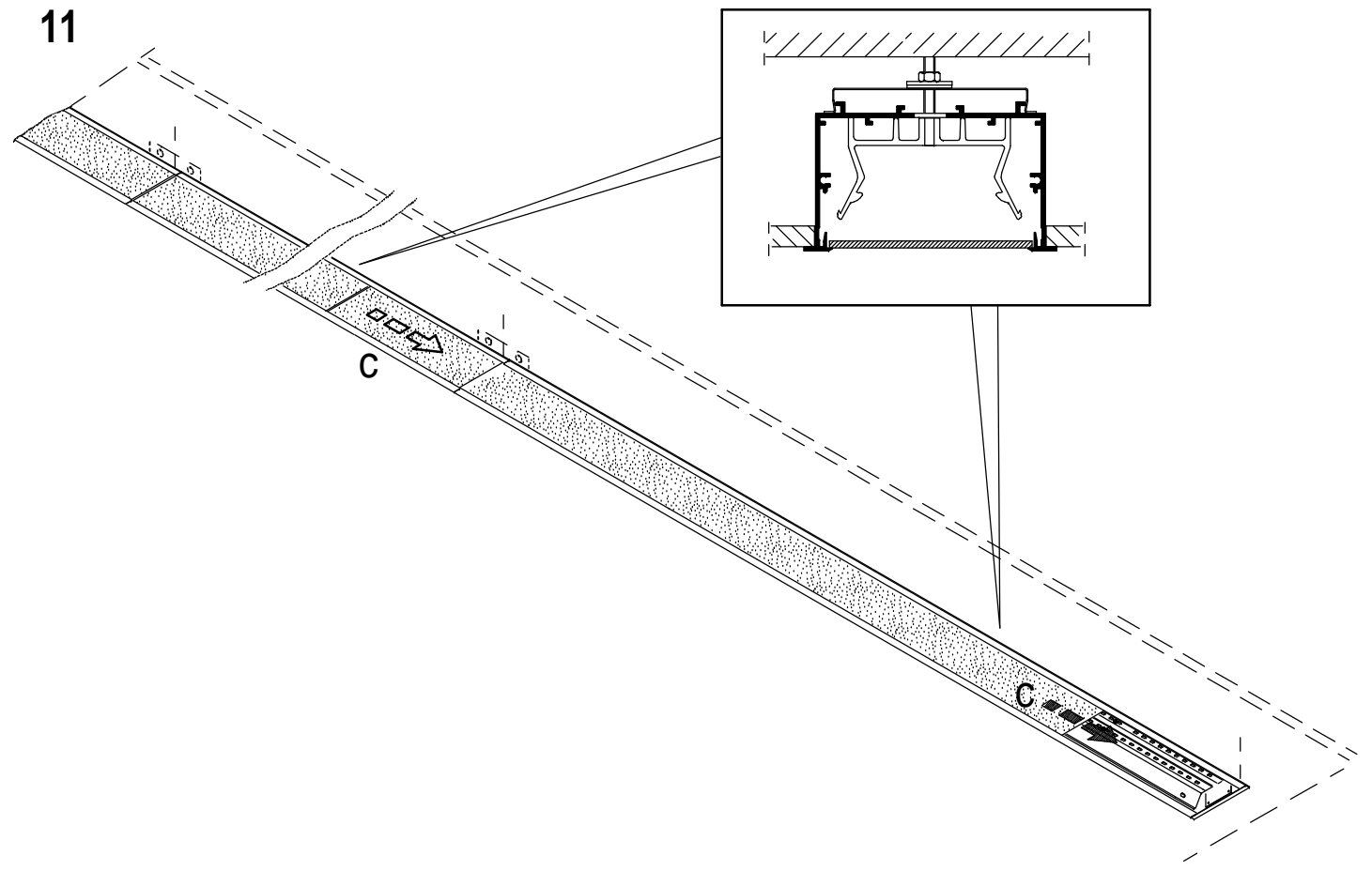

12

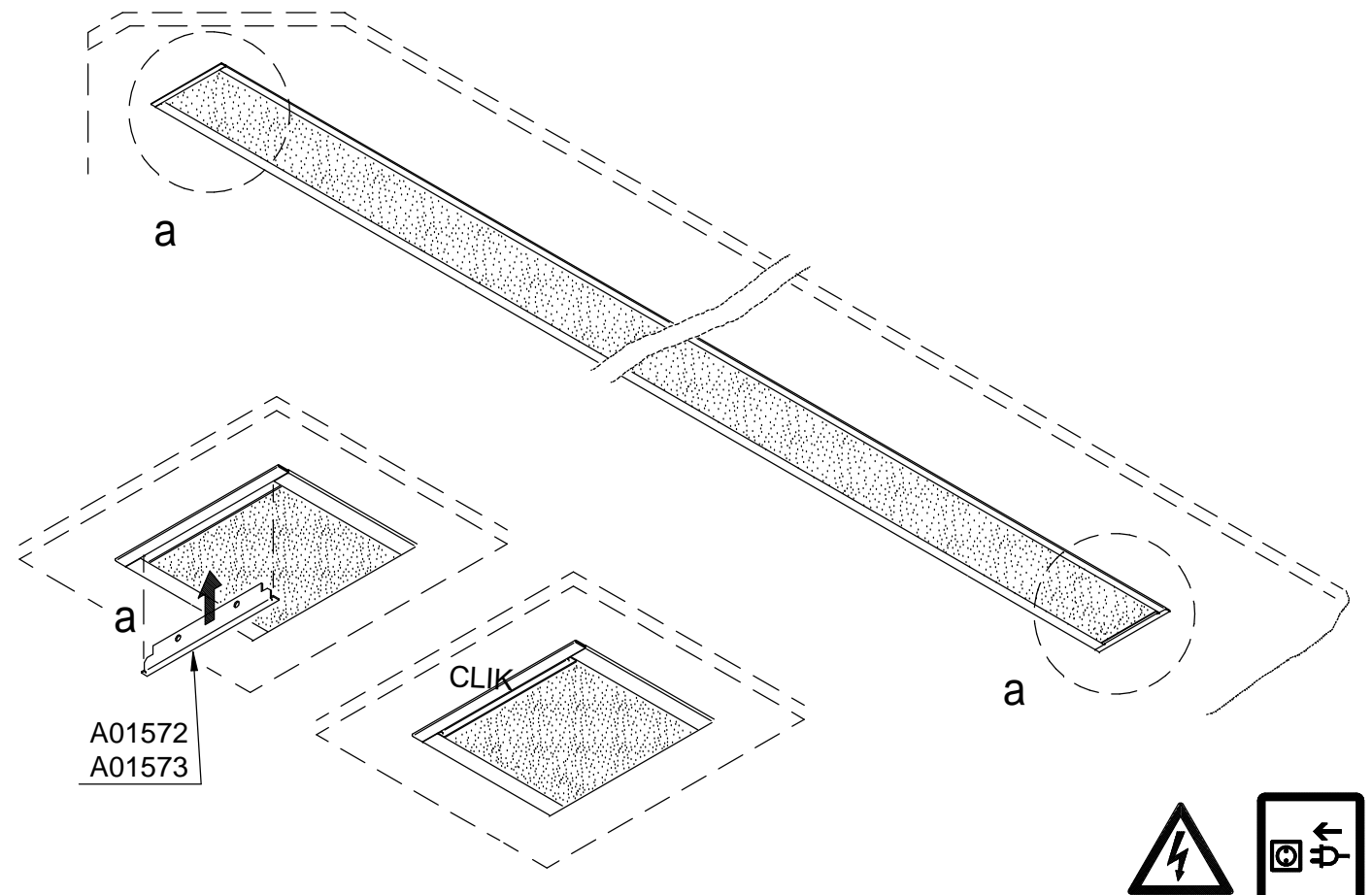
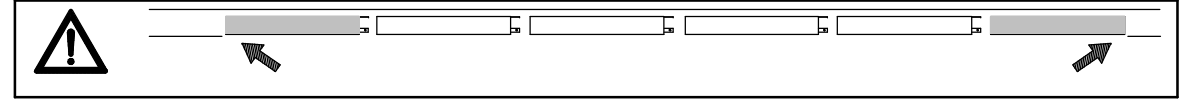

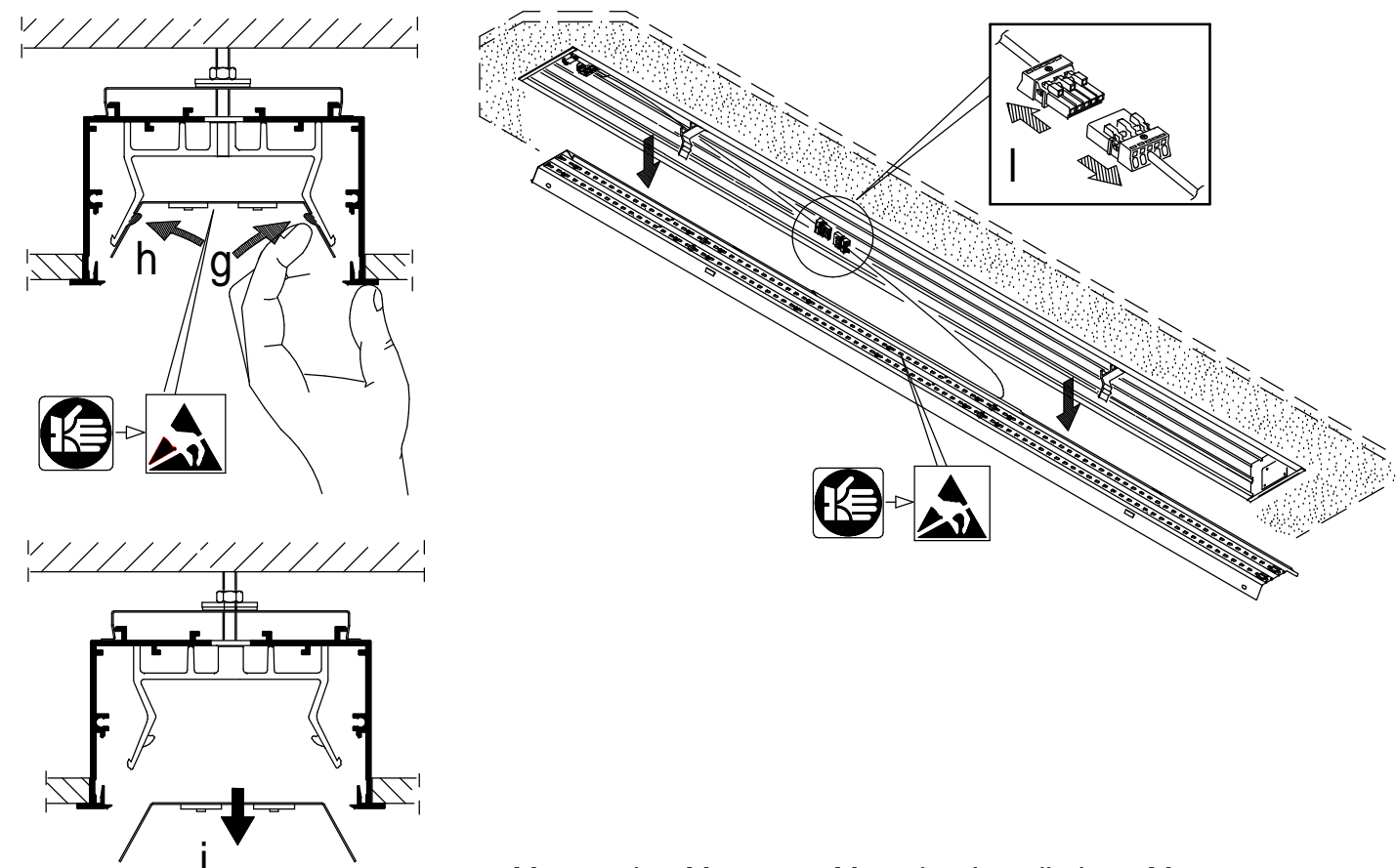
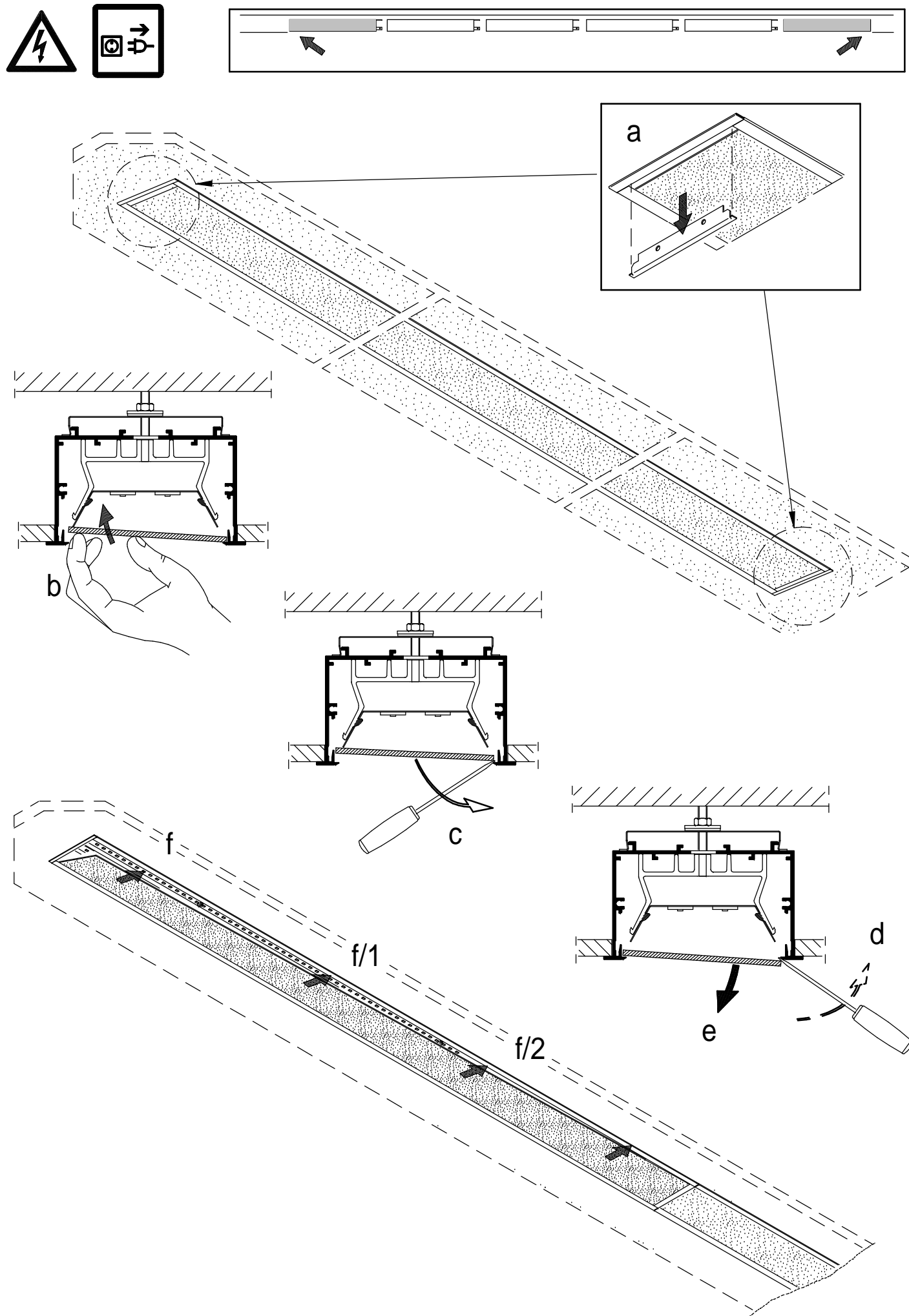

Montaggio - Montage - Montaje - Installation - Montage

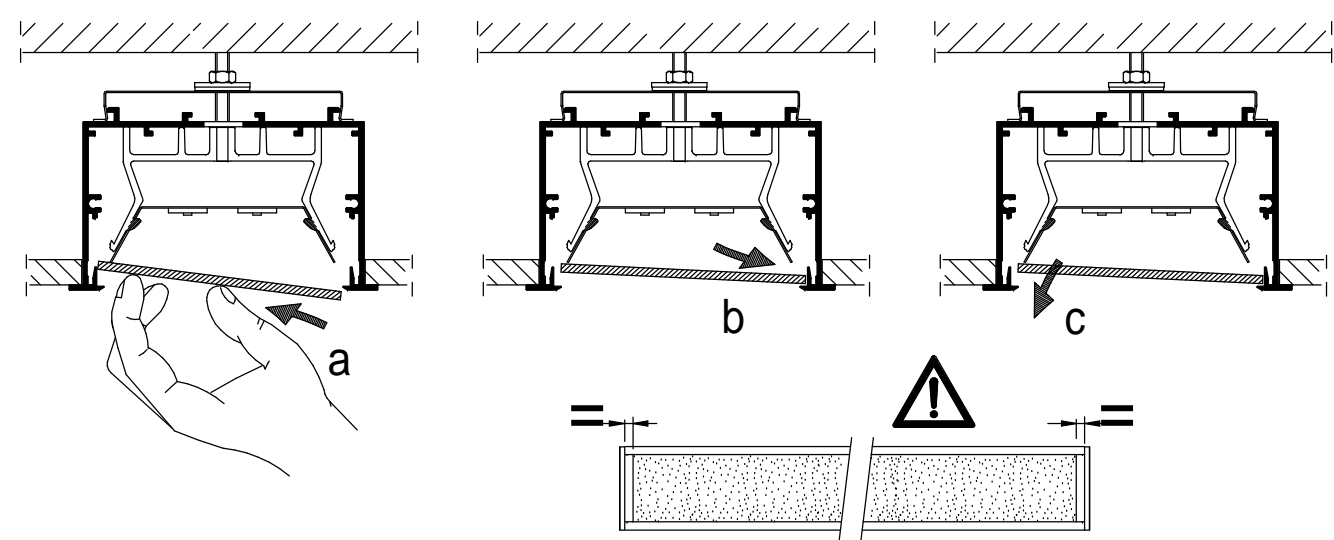

- La sorgente luminosa contenuta in questo apparecchio deve essere sostituita solo dal costruttore o dal suo servizio di assistenza o da personale altrettanto qualificato. Le norme nazionali di installazione devono essere rispettate. Prima di qualsiasi intervento
- The light source contained in this luminaire shall only be replaced by the manufacturer or his service agent or similar qualified person. National installation regulations must be observed. Before any work on the appliance, it must be disconnected from mains.
- Die in dieser Leuchte enthaltene Lichtquelle darf nur vom Hersteller oder seinem Servicemitarbeiter oder einer ähnlich qualifizierten Person ausgetauscht werden. Die nationalen Installationsvorschriften sind zu beachten. Vor jeder Arbeit an der Leuchte ist diese vom Netz zu trennen.
- La fuente de iluminación contenida en esta luminaria solo debe ser reemplazada por el fabricante o por su agente de servicio o por una persona igualmente calificada. Se deben respetar las normas nacionales de instalación. Antes de realizar cualquier trabajo en el aparato, debe desconectarse de la red eléctrica.
- La source lumineuse contenue dans ce luminaire ne doit être remplacée que par le fabricant ou par son agent de service ou par une personne également qualifiée. Les règles nationales d'installation doivent être respectées. Avant toute intervention sur l'appareil, il doit être débranché de son alimentation.

L'apparechio non deve essere smaltito come rifiuto urbano, mediante cassonetto, ma e' soggetto a raccolta separata.
Il mancato rispetto di questa norma e' sanzionato dalla legge e potrebbe provocare potenzialmente effetti negativi sia per l'ambiente sia sulla salute umana.



L'appareil ne doit pas être éliminé comme ordures ménagères, dans la poubelle, mais il est sujet à collecte sélective.
La non-observation de cette disposition est sanctionnée par la loi et peut provoquer en puissance effets négatifs soit pour l'ambiance soit pour la santé humaine.

La luminaria no debe ser desechada como residuo urbano, sino a través de un gestor de residuos, ya que es objeto de recogida selectiva.
El incumplimiento de esta norma está sancionado por la ley y puede causar potencialmente daños tanto al medio ambiente como a la salud.

The luminaire must not be eliminated as urban waste, by means of refuse body, rather it is object of separate collection.
The non-observance of this rule is sanctioned by the law and potentially could cause negative effects both on the environment and on human health.

Die Leuchte muss als Sondermüll entsorgt werden!
Die Nichteinhaltung dieser Bestimmung kann strafrechtlich verfolgt werden. Ferner verursacht eine nicht gerechte Entsorgung negative Folgen für die Umwelt und die menschliche Gesundheit.

DECRETO LEGISLATIVO 14 marzo 2014, n. 49. Attuazione della direttiva 2012/19/UE (Revisione della Direttiva 2002/96/UE) e s.m.i.